



ICE & REFRIGERATION

PRODUCT CATALOGUE 11 SEPTEMBER 2017



Hoshizaki Foodservice Equipment

www.hoshizaki.com.au

CONTENTS

PRODUCT CATALOGUE 11 SEPTEMBER 2017



5	BUILT ON STRONG FOUNDATIONS
6	ICE MAKERS - HOSHIZAKI ICE MACHINES
8	<i>Ice Cube Sizes & Shapes</i>
10	Cube Ice - IM Series
12	<i>IM-30CNE-25</i>
14	<i>IM-45CNE-25</i>
16	<i>IM-65NE-25</i>
18	<i>IM-100CNE-21</i>
20	<i>IM-100CNE-28</i>
22	<i>IM-130NE-21</i>
24	<i>IM-130NE-28</i>
26	<i>IM-240NE-21</i>
28	<i>IM-240NE-28</i>
30	<i>IM-240ANE-28</i>
32	<i>IM-240DNE Series</i>
34	<i>IM-65NE - Q Ball</i>
36	Flake Ice - FM Series
37	<i>FM-150KE Series</i>
39	<i>FM-480AKE Series</i>
41	<i>FM-750AKE Series</i>
43	<i>FM-1000AKE Series</i>
45	Crescent Ice - KM Series
46	<i>KM-30A</i>
48	<i>KM-50A</i>
50	<i>KM-75A</i>
52	<i>KM-100A</i>
54	<i>KM-125A</i>
56	<i>KMD-201AA</i>
58	<i>KMD-270AA</i>
60	<i>KM-650MAH</i>
62	<i>KM-901MAH-E</i>
64	<i>KM-1301SAH</i>
66	Cubelet Ice - Dispenser Series
67	<i>DCM-60KE-P Ice & Water Dispenser</i>
69	<i>DCM-120KE-P Ice & Water Dispenser</i>
71	<i>DB-200H Sanitary Ice Cube Dispenser</i>

Continued...



CONTENTS

PRODUCT CATALOGUE 11 SEPTEMBER 2017



73	Ice Storage Bins & Top Kits
74	B-301SA
76	B-501SA
78	B-801SA
80	B-1300SS
82	B-1500SS
84	Water Filters
86	PROFESSIONAL SERIES REFRIGERATION & FREEZERS
88	Product Highlights
91	Professional Counter Refrigeration & Freezers
92	RTE-120SDA-GN Counter Refrigerator
94	FTC-125SDA-GN Counter Freezer
96	RTE-170SDA-GN Counter Refrigerator
98	FTE-170SDA-GN Counter Freezer
100	Professional Upright Reach In Refrigeration & Freezers
101	HRE-70B Upright Reach In Refrigerator
103	HFE-70B Upright Freezer
105	HRE-140B Upright Reach In Refrigerator
107	HFE-140B Upright Reach In Freezer
109	COMMERCIAL SERIES REFRIGERATION & FREEZERS
111	Commercial Counter Series Refrigeration & Freezers
112	RTC-120MNA Counter Refrigerator
114	FTC-120MNA Counter Freezer
116	RTC-150MNA Counter Refrigerator
118	FTC-150MNA Counter Freezer
120	RTC-180MNA Counter Refrigerator
122	FTC-180MNA Counter Freezer
124	Commercial Series Upright Reach In Refrigeration & Freezers
125	HRE-77MA Upright Refrigerator
127	HFE-77MA Upright Freezer
129	HRE-127MA Upright Refrigerator
131	HFE-127MA Upright Freezer
133	HRE-147MA Upright Refrigerator
135	HFE-147MA Upright Freezer
137	HRE-187MA Upright Refrigerator
139	HFE-187MA Upright Freezer

Continued...



CONTENTS

PRODUCT CATALOGUE 11 SEPTEMBER 2017

141

SUSHI CABINETS

143

HNC-120BE-L Counter Showcase

145

HNC-150BE-L Counter Showcase

147

HNC-180BE-R-B Counter Showcase

149

HOSHIZAKI SPARE PARTS

150

ACCREDITATION AND TERMS



BUILT ON STRONG FOUNDATIONS

OUR COOL AND CLEAN MISSION

With over 60 years of experience in the commercial kitchen equipment and food service markets, Hoshizaki is a global market leader.

Hoshizaki designed and developed Japan's first fully automatic ice maker and from this pioneering base we have an ice making and refrigeration product range that exceeds expectations in the demanding sectors of food, beverage, bars and restaurants, bio-science, healthcare and education.

Hoshizaki has rightfully gained an international reputation for sustainable innovation, durability and reliability. All machines are designed and specified by Hoshizaki's dedicated Japanese Research and Development team, which ensures Hoshizaki continues to devise innovative and sustainable products that cement the company's position as one of the world's visionary suppliers.

The company is noted for developing energy and water efficient, environmentally friendly (Hydro Fluorocarbon free) ice makers, adding value for the end-user through cost-saving and sustainability. Hoshizaki also innovates in the sectors it operates, for example in hospitality end-users can choose ice-makers that produce different types of ice from ball ice to flaked, which make the difference in quality beverages such as cocktails.

Find out more. Please visit www.hoshizaki.com.au





ICE MAKERS - HOSHIZAKI ICE MACHINES



Hoshizaki Foodservice Equipment

www.hoshizaki.com.au

ICE MAKERS - HOSHIZAKI ICE MACHINES

Hoshizaki is widely considered to be one of the world's leading manufacturers of ice makers. Our superior reliability ensures customers can depend on our ice machines day in, day out, year after year. Here are just a few reasons why...

ICE MACHINE RELIABILITY

Hoshizaki is the world's number one ice maker, with over 60 years of creating the world's best ice. Our product engineering, manufacture quality control and quality of internal components are what make Hoshizaki ice machines the industry standard.

We are also the only Australian company in our industry to achieve three externally recognised certifications for our Quality, Safety and Environmental systems. In addition Hoshizaki Ice Makers & Storage Bins are HACCP certified.

THE WORLD'S BEST ICE...

Hoshizaki ice machines consistently and reliably create better ice than any other ice makers;

- *the ice is clear and hard, not cloudy*
- *the ice presents very well, particularly in spirit drinks*
- *the ice has the highest displacement than any other ice*
- *the ice retains its shape; the cube ice is a genuine cube*
- *the crescent ice allows pouring and nipping of spirits without splash*
- *the ice doesn't bridge while in the ice storage bin*
- *the ice has the slowest melt rate, because it is clear and hard*

COMMERCIAL ICE MAKERS

Our commercial ice machines range encompasses many industrial ice makers that make different types of ice for different uses across a wide span of industry sectors. However, all our ice machines are of the high quality standard that is associated with Hoshizaki.

Models include ice makers for cube ice, cubelet ice, crescent ice, flake ice, scale ice and ice dispensers with models suitable for a small café or bar right through to large, modular, industrial ice machine models.

ICE MACHINE RESEARCH & DEVELOPMENT

All ice machines are originally designed and specified by a massive Japanese Research & Development team employing over 150 engineers. The basic designs and major component parts are specified for a global market meaning that Hoshizaki ice machines will effortlessly and quickly achieve outstanding levels of efficiency in ambient temperatures of between 40°C and 10°C – even in humid environments.

Hoshizaki ice machine parts are precision engineered exclusively for each ice maker to further enhance the most efficient operation. Our ice storage bins are foam injected with insulated, precision made doors with gaskets to create a closed environment that minimises meltage and thus decreases the number of ice production cycles.



ICE CUBE SIZES & SHAPES

ICE CUBE SIZES

Hoshizaki ice machines produce exceptionally hard, pure ice cubes.

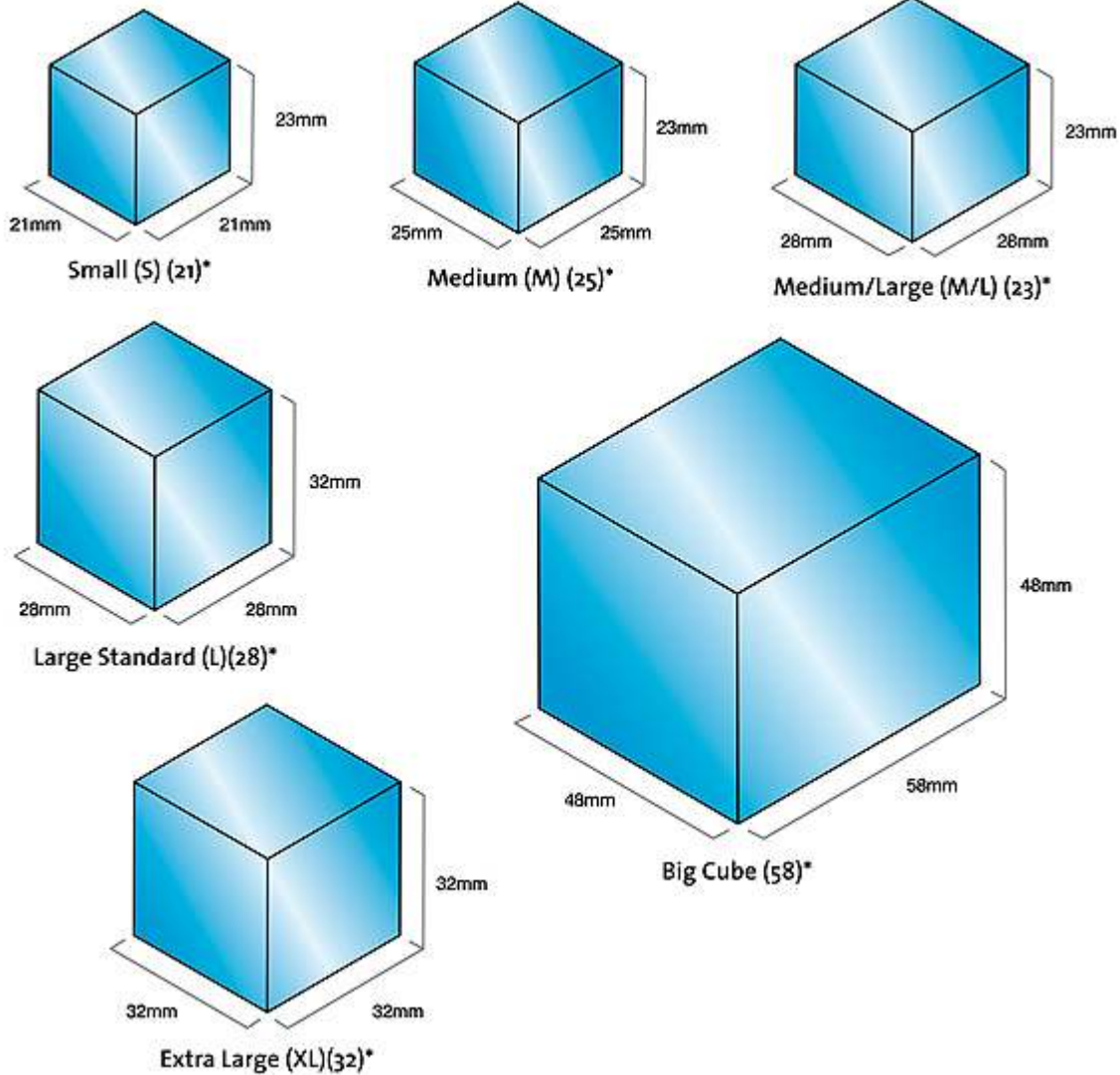

* Size of Ice Cube mentioned in brackets () is reflected in product names of the IM Series, eg (21) in IM-CNE-21 refers to a Cube Size Small.

ICE CUBE SIZES & SHAPES

ICE SIZES & SHAPES

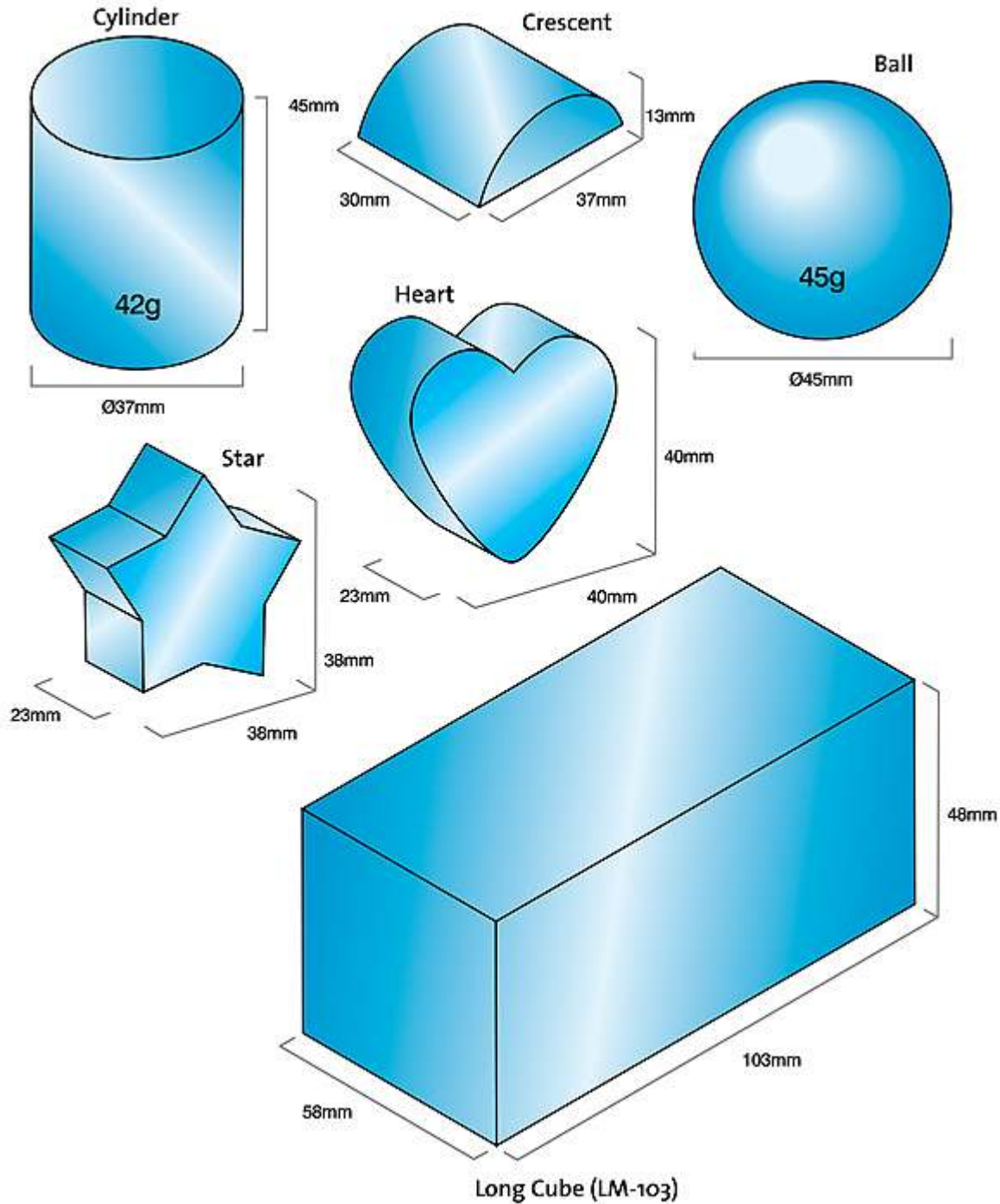

*Contact Hoshizaki Sales office for price & availability.

CUBE ICE - IM SERIES

IM PRODUCT HIGHLIGHTS



Hoshizaki IM Machines utilise a closed cell ice making system that has an automatic flush cycle.



A stainless steel exterior with integrated door handles provides a hygienic and high quality finish.



Removeable door gaskets prevent any heat and contamination from entering the bin and make the Hoshizaki product easy to clean and maintain.



A closed water circuit offers the ultimate contamination protection, by reducing the number of points at which impurities can enter the ice making process.



An easily cleanable air filter allows users to carry out a routine cleaning schedule themselves, extending the life expectancy of your Hoshizaki ice maker, and cutting the frequency and cost of maintenance call-outs.



Ice machines are computer controlled so the ice making process is optimised under varying circumstances without the need for physical adjustments.

Foam injected polyurethane for outstanding insulation (HFC free) preserves the quality and consistency of the ice produced longer than any other machine available. This reduces the number of production cycles, saving energy and money.

CUBE ICE - IM SERIES

ICE PRODUCTION PROCESS

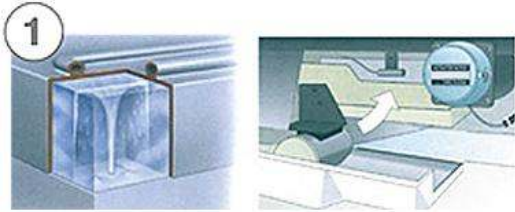

With the water plate closed against the underside of the evaporator, the water circuit is closed to both outside contamination and water loss under normal circumstances. Crucially, each cube is made individually by a dedicated spray to ensure the highest possible ice quality.

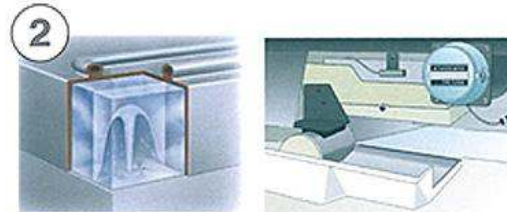

As the ice cube slowly forms the spray continues until the end of the cycle. No fresh water is required as the internal reservoir capacity is adequate for a full cycle of ice.

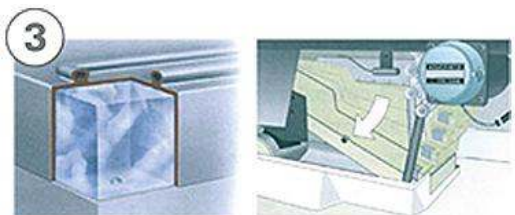

When the cube is fully formed the electronic controller initiates a hot gas defrost cycle. The water plate opens and the hot gas slowly warms the evaporator.

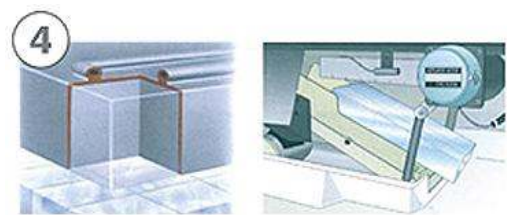

The ice will drop from the evaporator into the ice bin. The water plate will be rinsed with fresh water to remove any remaining particles before it starts to close again. Fresh water continues to enter until the reservoir is full to enable a new freeze cycle to commence.

IM-30CNE-25



WaterMark

ATS 5200.105
22349, 22350, 22351

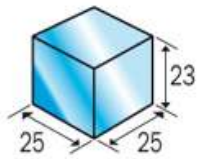

Medium

Product Specifications

COOLING	Air
WEIGHT	Net: 34kg Packed: 38kg
AC SUPPLY VOLTAGE	220 - 240V / 50Hz 10Amps
REFRIGERANT	R134a
AMBIENT	1 - 40°C
WATER TEMP	5 - 35°C
WATER PRESSURE	50 - 800kPa
ICE PRODUCTION PER 24 HOURS (APPROX)	Air temp: 10°C Water temp: 10°C - 22kg Air temp: 21°C Water temp: 15°C - 18kg Air temp: 32°C Water temp: 21°C - 18kg
ICE PRODUCTION PER CYCLE	0.27kg / 21pcs
FREEZE CYCLE	19mins
MAX STORAGE CAPACITY	11.5kg
BIN CONTROL	6kg

Product Range

PART NO.	DESCRIPTION	LIST PRICE
91000001	IM-30CNE-25	



IM-30CNE-25

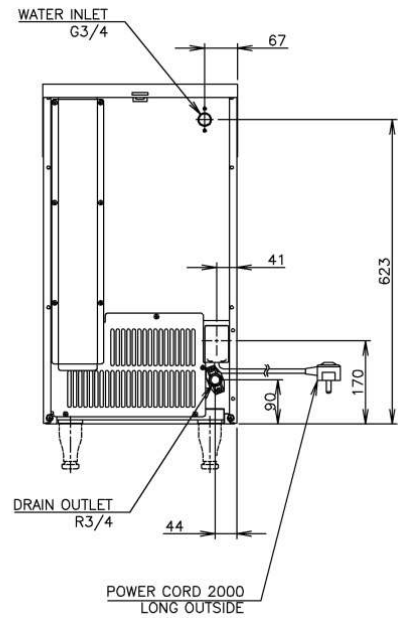
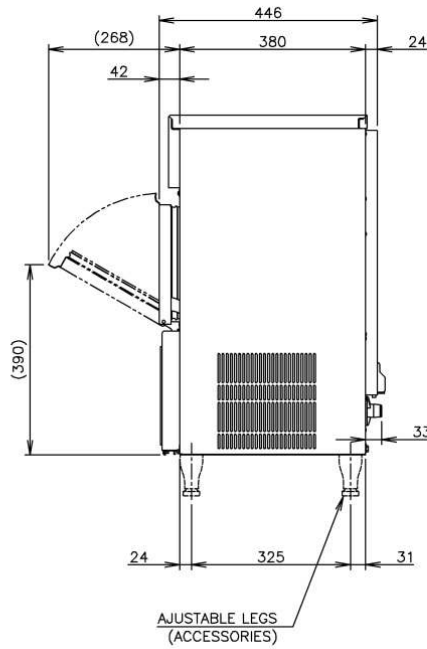
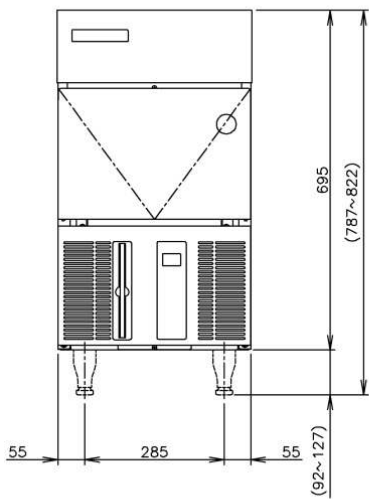
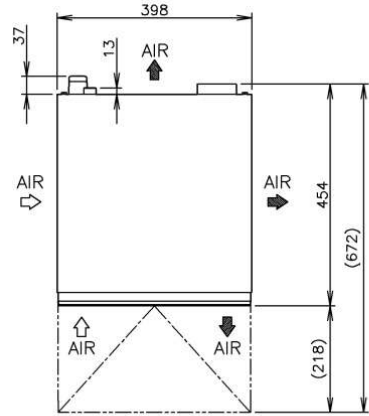

IM-45CNE-25



WaterMark

ATS 5200.105
22349, 22350, 22351

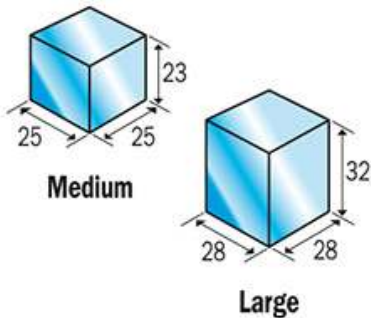

Product Specifications

COOLING	Air
WEIGHT	Net: 48kg Packed: 55kg
AC SUPPLY VOLTAGE	220 - 240V / 50Hz 10Amps
REFRIGERANT	R134a
AMBIENT	1 - 40°C
WATER TEMP	5 - 35°C
WATER PRESSURE	50 - 800kPa
ICE PRODUCTION PER 24 HOURS (APPROX)	Air temp: 10°C Water temp: 10°C - 35kg Air temp: 21°C Water temp: 15°C - 32kg Air temp: 32°C Water temp: 21°C - 27kg
ICE PRODUCTION PER CYCLE	0.55kg / 42pcs
FREEZE CYCLE	22mins
MAX STORAGE CAPACITY	15kg
BIN CONTROL	8kg

Product Range

PART NO.	DESCRIPTION	LIST PRICE
91000090	IM-45CNE-25	



IM-45CNE-25

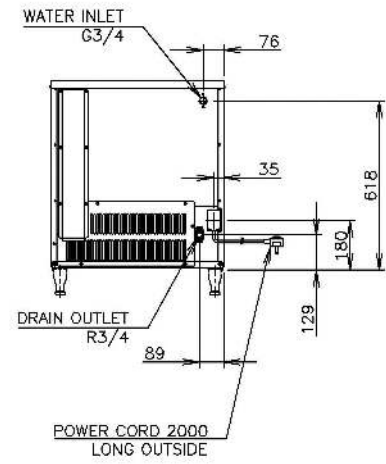
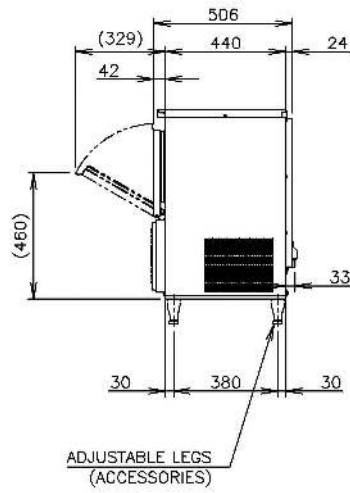
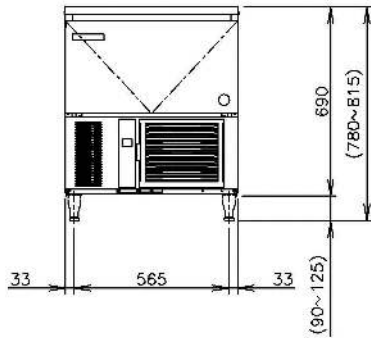
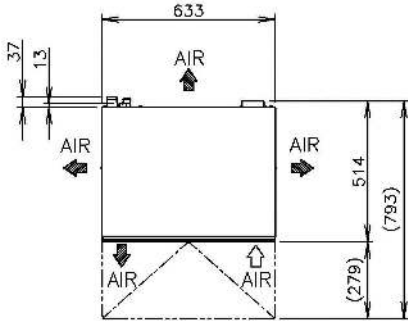

IM-65NE-25



WaterMark

ATS 5200.105
22349, 22350, 22351

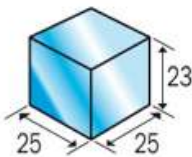

Medium

Product Specifications

COOLING	Air
WEIGHT	Net: 53kg Packed: 60kg
AC SUPPLY VOLTAGE	220 - 240V / 50Hz 10Amps
REFRIGERANT	R134a
AMBIENT	1 - 40°C
WATER TEMP	5 - 35°C
WATER PRESSURE	50 - 800kPa
ICE PRODUCTION PER 24 HOURS (APPROX)	Air temp: 10°C Water temp: 10°C - 45kg Air temp: 21°C Water temp: 15°C - 44kg Air temp: 32°C Water temp: 21°C - 37kg
ICE PRODUCTION PER CYCLE	0.67kg / 56 pcs
FREEZE CYCLE	22mins
MAX STORAGE CAPACITY	26kg
BIN CONTROL	18kg

Product Range

PART NO.	DESCRIPTION	LIST PRICE
91000097	IM-65NE-25	



IM-65NE-25

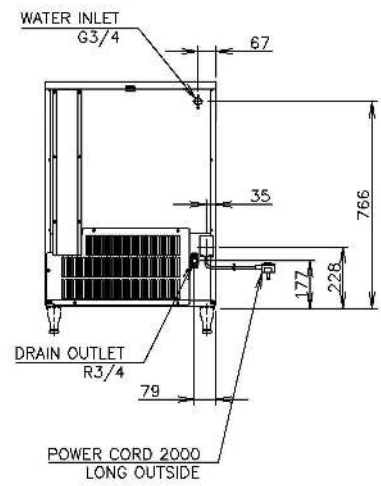
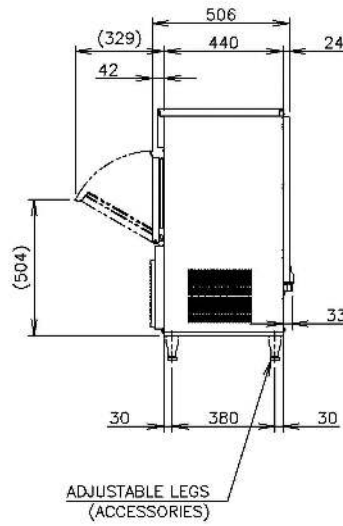
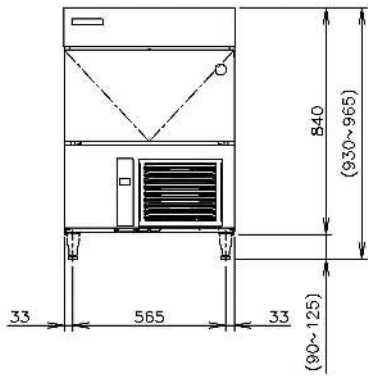
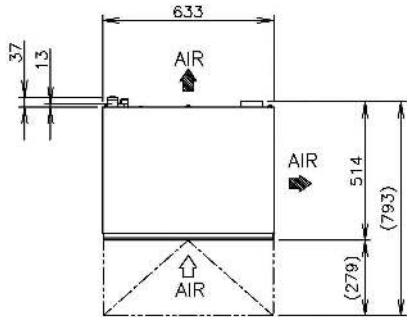

IM-100CNE-21



<i>Product Specifications</i>	
<i>Cooling</i>	Air
<i>Weight</i>	Net: 77kg Gross: 88kg
<i>AC Supply Voltage</i>	220 - 240V / 50Hz
<i>Refrigerant</i>	R134a
<i>Ambient</i>	1 - 40°C
<i>Water Temp</i>	5 - 35°C
<i>Water Pressure</i>	70 - 800kPa
<i>Ice Production Per 24 Hours (Approx)</i>	Air temp: 10°C Water temp: 10°C - 90kg Air temp: 21°C Water temp: 15°C - 85kg Air temp: 32°C Water temp: 21°C - 62kg
<i>Ice Production Per Cycle</i>	1.15kg / 190pcs
<i>Freeze Cycle</i>	17min
<i>Max Storage Capacity</i>	38kg
<i>Bin Control</i>	23kg

<i>Product Range</i>		
<i>PART NO.</i>	<i>DESCRIPTION</i>	<i>LIST PRICE</i>
91000117	IM-100CNE-21	

IM-100CNE-21

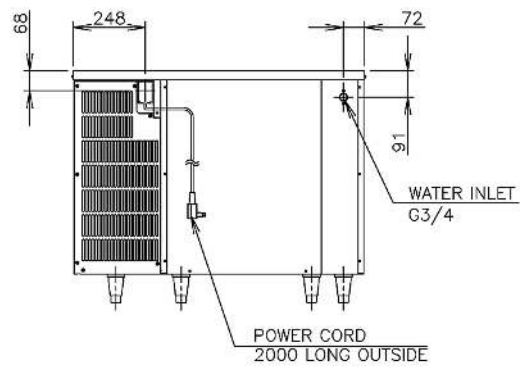
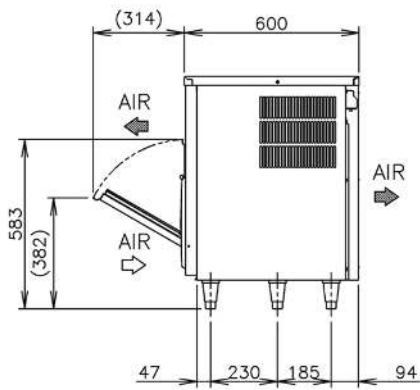
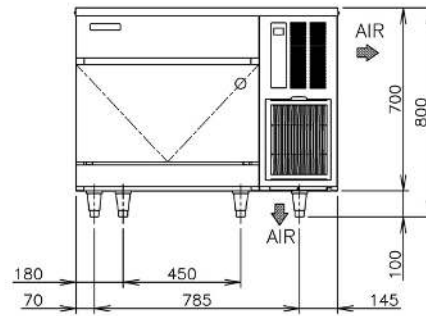
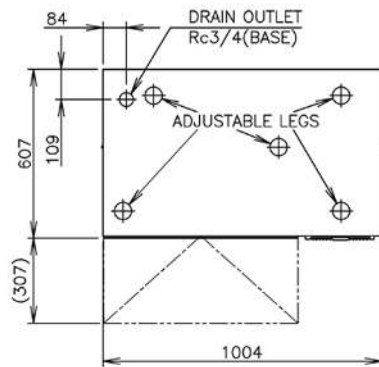

IM-100CNE-28



<i>Product Specifications</i>	
<i>Cooling</i>	Air
<i>Weight</i>	Net: 77kg Gross: 90kg
<i>AC Supply Voltage</i>	220 - 240V / 50Hz
<i>Refrigerant</i>	R134a
<i>Ambient</i>	1 - 40°C
<i>Water Temp</i>	5 - 35°C
<i>Water Pressure</i>	70 - 800kPa
<i>Ice Production Per 24 Hours (Approx)</i>	Air temp: 21°C Water temp: 15°C - Up to 85kg Air temp: 32°C Water temp: 21°C - Up to 73kg
<i>Ice production per cycle</i>	1.15kg / 190pcs?
<i>Freeze Cycle</i>	17min
<i>Max Storage Capacity</i>	38kg
<i>Bin Control</i>	23kg

<i>Product Range</i>		
<i>PART NO.</i>	<i>DESCRIPTION</i>	<i>LIST PRICE</i>
91000114	IM-100CNE-28	



IM-100CNE-28

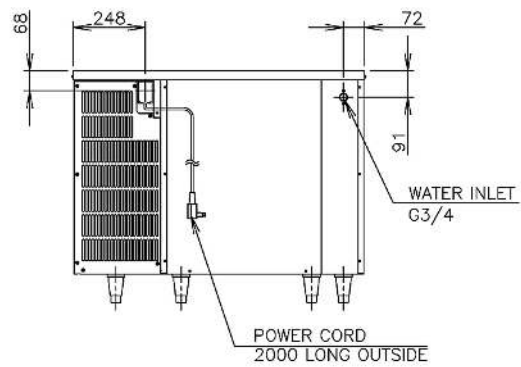
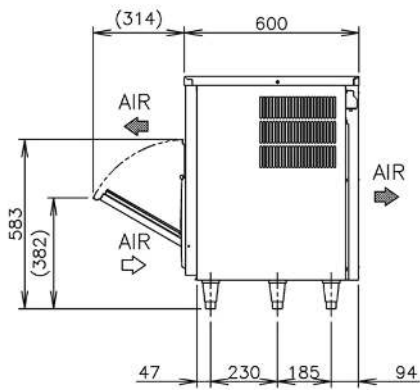
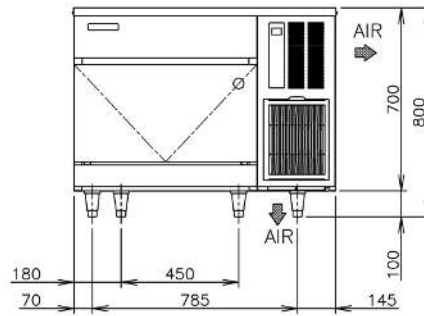
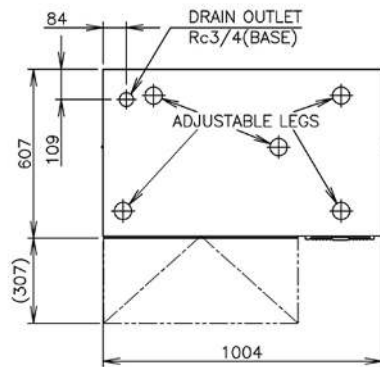

IM-130NE-21



WaterMark

ATS 5200.105
22349, 22350, 22351

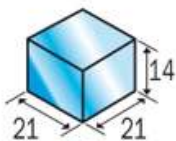

Small

Product Specifications

COOLING	Air
WEIGHT	Net: 76kg Packed: 84kg
AC SUPPLY VOLTAGE	220 - 240V / 50Hz 10Amps
REFRIGERANT	R404A
AMBIENT	1 - 40°C
WATER TEMP	5 - 35°C
WATER PRESSURE	50 - 800kPa
ICE PRODUCTION PER 24 HOURS (APPROX)	Air temp: 10°C Water temp: 10°C - 104kg Air temp: 21°C Water temp: 15°C - 95kg Air temp: 32°C Water temp: 21°C - 82kg
ICE PRODUCTION PER CYCLE	1.15kg / 190 pcs
FREEZE CYCLE	19mins
MAX STORAGE CAPACITY	50kg
BIN CONTROL	28kg

Product Range

PART NO.	DESCRIPTION	LIST PRICE
91000118	IM-130NE-21	
91000106	IM-130NE-28	



IM-130NE-21

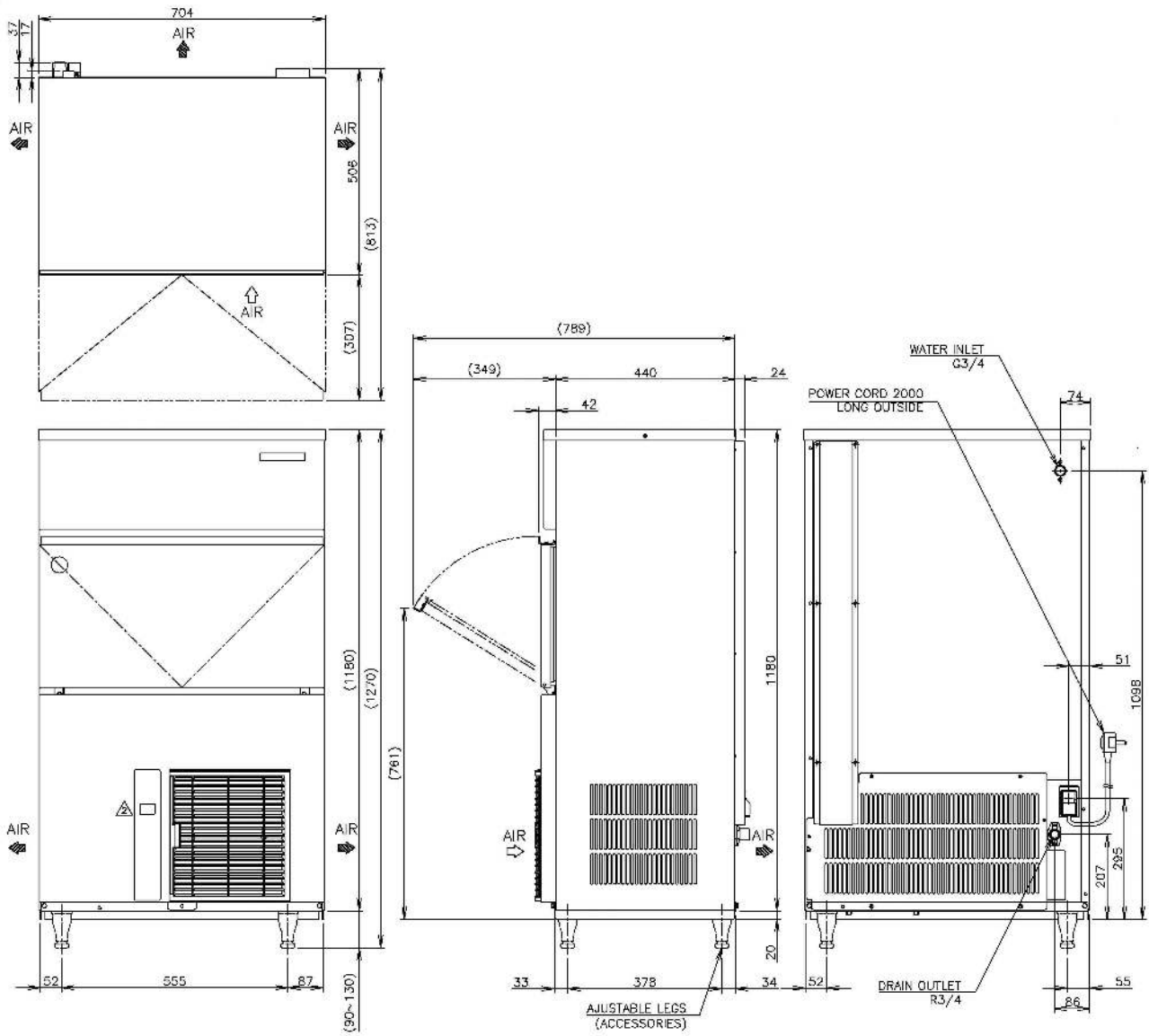

IM-130NE-28



WaterMark

ATS 5200.105
22349, 22350, 22351

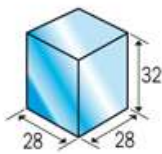

Large

Product Specifications

COOLING	Air
WEIGHT	Net: 76kg Packed: 84kg
AC SUPPLY VOLTAGE	220 - 240V / 50Hz 10Amps
REFRIGERANT	R404A
AMBIENT	1 - 40°C
WATER TEMP	5 - 35°C
WATER PRESSURE	50 - 800kPa
ICE PRODUCTION PER 24 HOURS (APPROX)	Air temp: 10°C Water temp: 10°C - 104kg Air temp: 21°C Water temp: 15°C - 100kg Air temp: 32°C Water temp: 21°C - 88kg
ICE PRODUCTION PER CYCLE	1.8kg / 80pcs
FREEZE CYCLE	22mins
MAX STORAGE CAPACITY	50kg
BIN CONTROL	28kg

Product Range

PART NO.	DESCRIPTION	LIST PRICE
91000106	IM-130NE-28	
91000118	IM-130NE-21	



IM-130NE-28

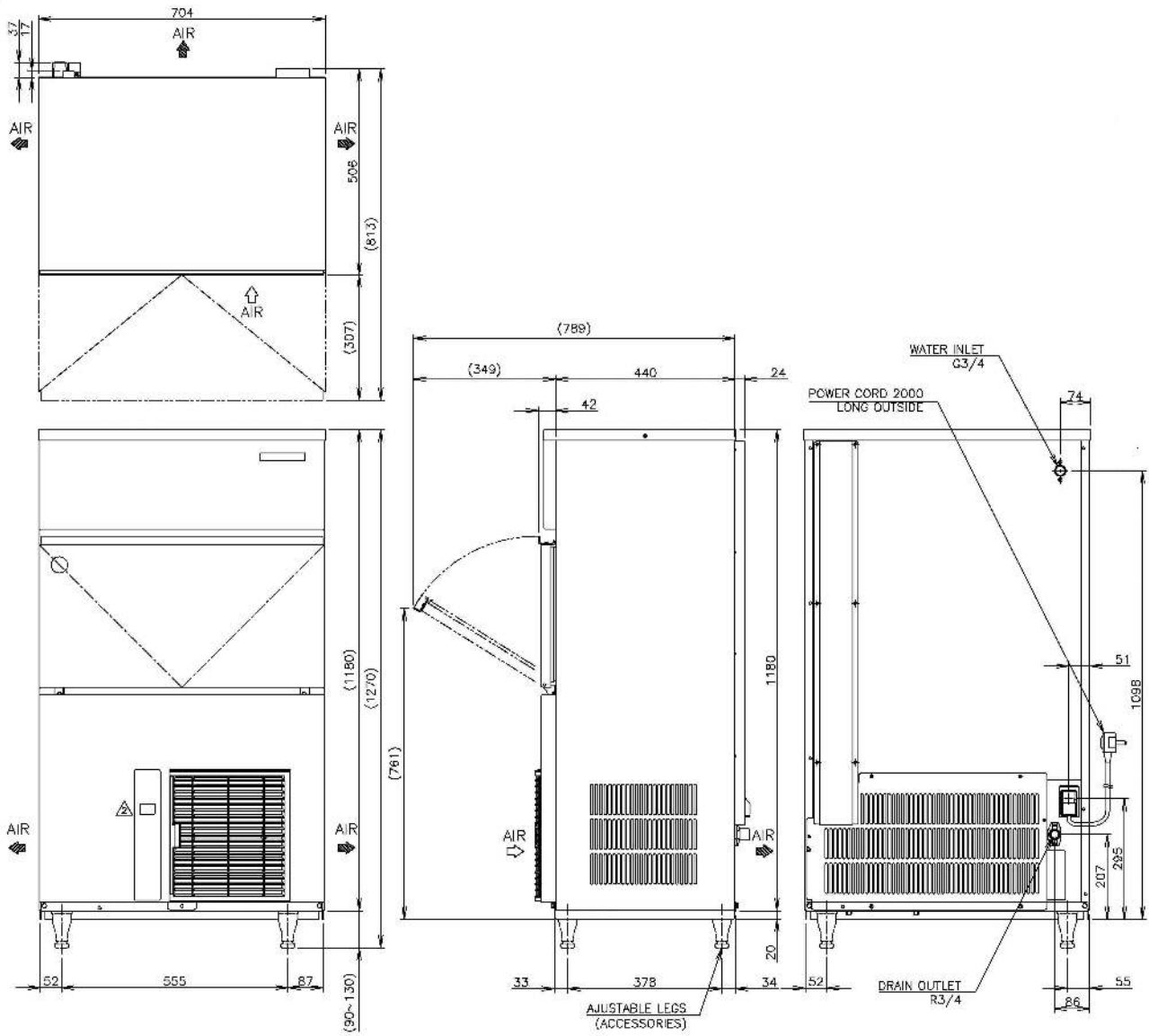

IM-240NE-21



WaterMark

ATS 5200.105
22349, 22350, 22351

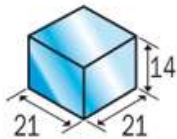

Small

Product Specifications

COOLING	Air
WEIGHT	Net: 111kg Packed: 122kg
AC SUPPLY VOLTAGE	220 - 240V / 50Hz 10Amps
REFRIGERANT	R404A
AMBIENT	1 - 40°C
WATER TEMP	5 - 35°C
WATER PRESSURE	50 - 800kPa
ICE PRODUCTION PER 24 HOURS (APPROX)	Air temp: 10°C Water temp: 10°C - 180kg Air temp: 21°C Water temp: 15°C - 175kg Air temp: 32°C Water temp: 21°C - 165kg
ICE PRODUCTION PER CYCLE	2.38kg / 140pcs
FREEZE CYCLE	11mins
MAX STORAGE CAPACITY	110kg
BIN CONTROL	80kg

Product Range

PART NO.	DESCRIPTION	LIST PRICE
91000112	IM-240NE-21	
91000091	IM-240NE-28	



IM-240NE-21

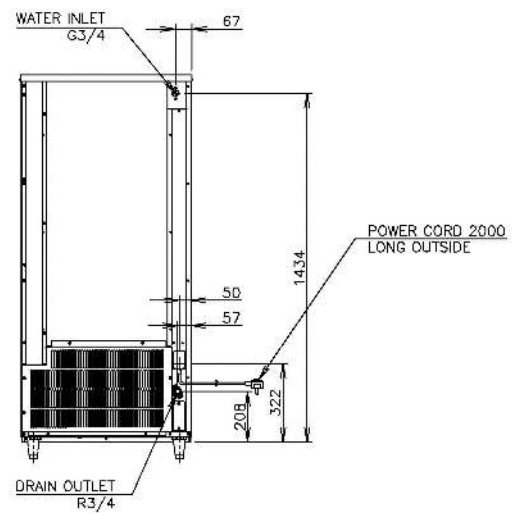
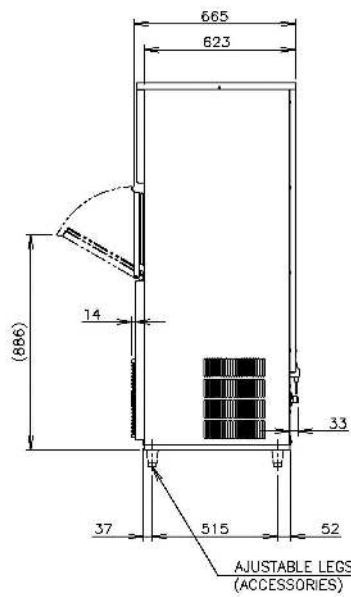
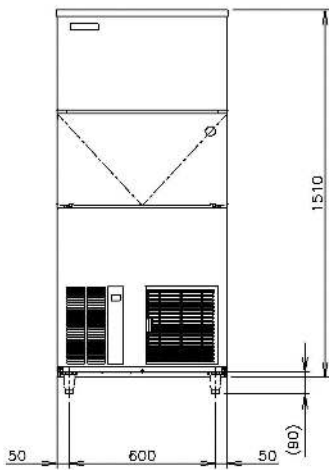
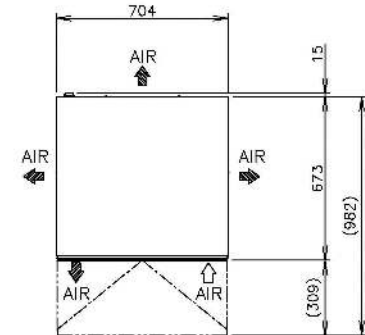

IM-240NE-28



WaterMark

ATS 5200.105
22349, 22350, 22351

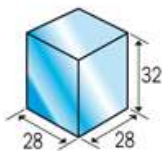

Large

Product Specifications

COOLING	Air
WEIGHT	Net: 111kg Packed: 122kg
AC SUPPLY VOLTAGE	220 - 240V / 50Hz 10Amps
REFRIGERANT	R404A
AMBIENT	1 - 40°C
WATER TEMP	5 - 35°C
WATER PRESSURE	50 - 800kPa
ICE PRODUCTION PER 24 HOURS (APPROX)	Air temp: 10°C Water temp: 10°C - 230kg Air temp: 21°C Water temp: 15°C - 210kg Air temp: 32°C Water temp: 21°C - 195kg
ICE PRODUCTION PER CYCLE	3.2kg / 140pcs
FREEZE CYCLE	20mins
MAX STORAGE CAPACITY	110kg
BIN CONTROL	80kg

Product Range

PART NO.	DESCRIPTION	LIST PRICE
91000112	IM-240NE-21	
91000091	IM-240NE-28	



IM-240NE-28

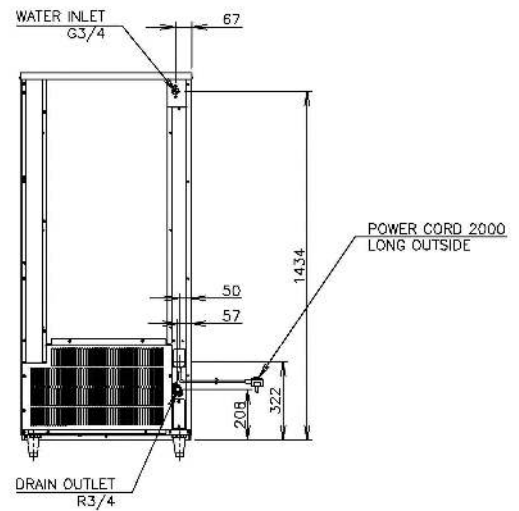
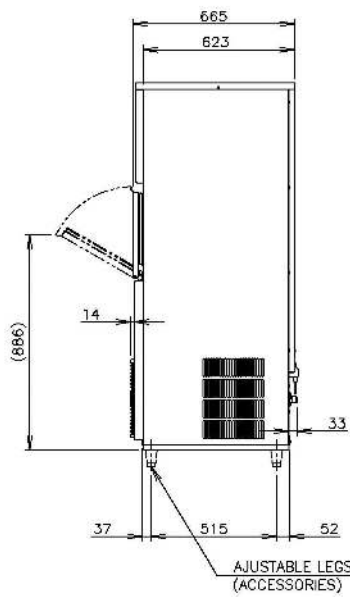
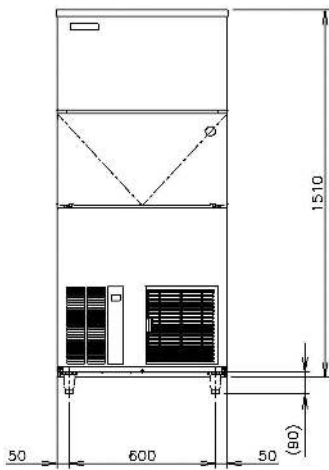
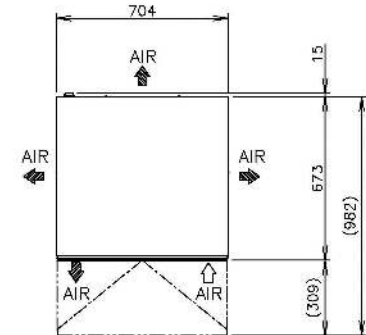

IM-240ANE-28



WaterMark

ATS 5200.105
22349, 22350, 22351

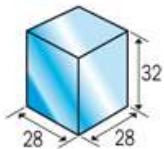

Large

Product Specifications

COOLING	Air
WEIGHT	Net: 80kg Packed: 91kg
AC SUPPLY VOLTAGE	220 - 240V / 50Hz 10Amps
REFRIGERANT	R404A
AMBIENT	1 - 40°C
WATER TEMP	5 - 35°C
WATER PRESSURE	50 - 800kPa
ICE PRODUCTION PER 24 HOURS (APPROX)	Air temp: 10°C Water temp: 10°C - 220kg Air temp: 21°C Water temp: 15°C - 205kg Air temp: 32°C Water temp: 21°C - 160kg
ICE PRODUCTION PER CYCLE	3.2kg / 140pcs
FREEZE CYCLE	20mins
MAX STORAGE CAPACITY	Select Bin

Product Range

PART NO.	DESCRIPTION	LIST PRICE
91000098	IM-240ANE-28	



IM-240ANE-28

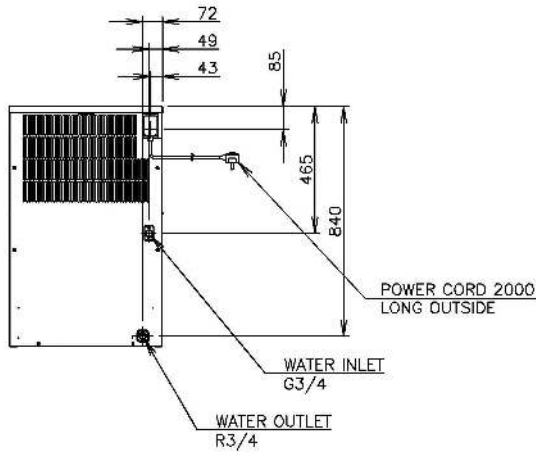
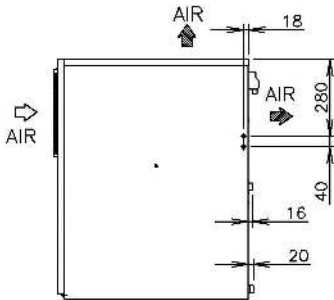
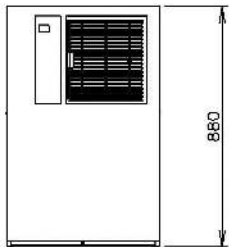
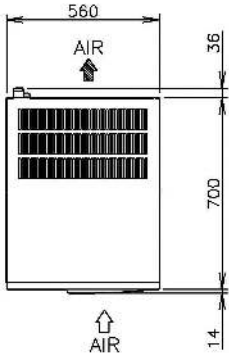

IM-240DNE SERIES



WaterMark

ATS 5200.105
22349, 22350, 22351

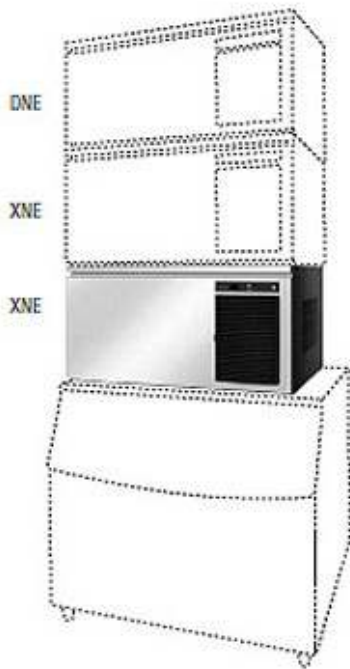

Product Specifications

COOLING	Air
WEIGHT - DNE SERIES	Net: 88kg Packed: 106kg
WEIGHT - XNE SERIES	Net: 84kg Packed: 102kg
AC SUPPLY VOLTAGE	220 - 240V / 50Hz 10Amps
REFRIGERANT	R404A
AMBIENT	1 - 40°C
WATER TEMP	5 - 35°C
WATER PRESSURE	50 - 800kPa
ICE PRODUCTION PER 24 HOURS (APPROX)	Air temp: 10°C Water temp: 10°C - 190kg Air temp: 21°C Water temp: 15°C - 180kg Air temp: 32°C Water temp: 21°C - 165kg
ICE PRODUCTION PER CYCLE	2.1kg / 360pcs
FREEZE CYCLE	15min

Product Range

PART NO.	DESCRIPTION	LIST PRICE
91000109	IM-240DNE-28	



IM-240DNE SERIES

IM-240DNE-21

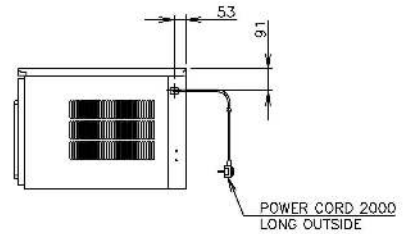
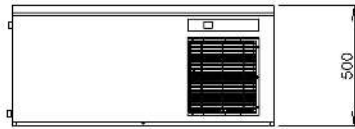
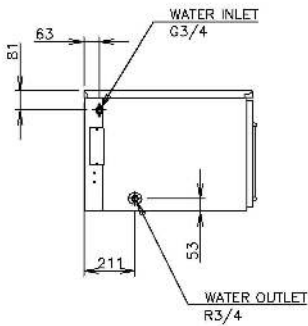
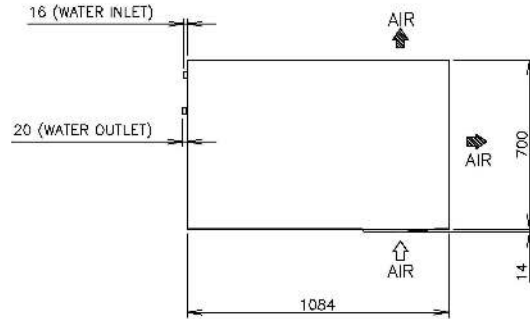

IM-240XNE-21

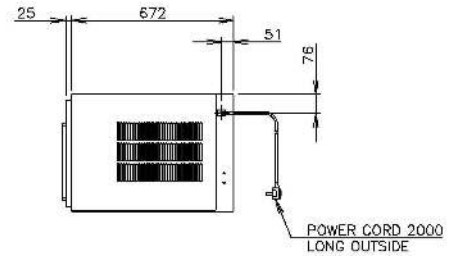
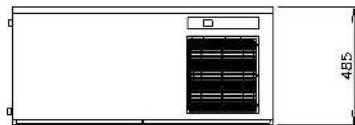
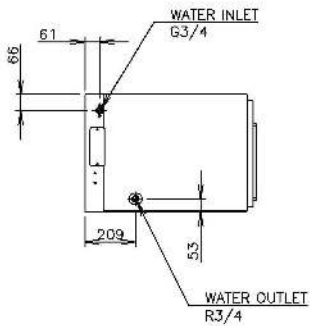
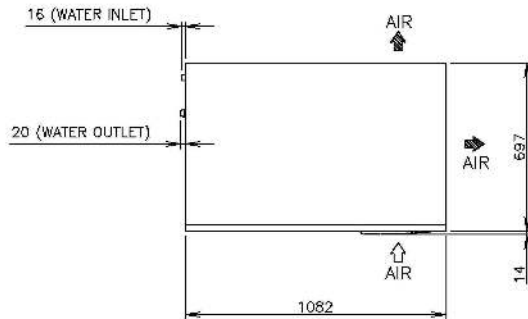

IM-65NE - Q BALL



<i>Product Specifications</i>	
<i>Weight</i>	Net: 53kg Gross: 66kg
<i>AC Supply Voltage</i>	220 - 240V / 50Hz 10Amps
<i>Refrigerant</i>	R134a
<i>Ambient</i>	1 - 40°C
<i>Water Temp</i>	5 - 35°C
<i>Water Pressure</i>	0.07 - 0.8MPa
<i>Ice Production Per 24 Hours (Approx)</i>	Air temp: 10°C Water temp: 10°C - 26kg Air temp: 21°C Water temp: 15°C - 24kg Air temp: 32°C Water temp: 21°C - 20kg
<i>Ice Production Per Cycle</i>	0.67kg / 15pcs
<i>Freeze Cycle</i>	33mins
<i>Max Storage Capacity</i>	17kg
<i>Bin Control</i>	9kg

<i>Product Range</i>		
<i>PART NO.</i>	<i>DESCRIPTION</i>	<i>LIST PRICE</i>
91000096	IM-65NEQ Ball Ice	

IM-65NE - Q BALL

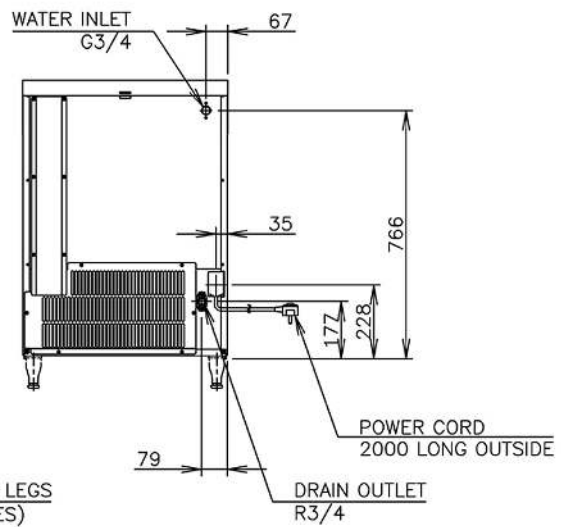
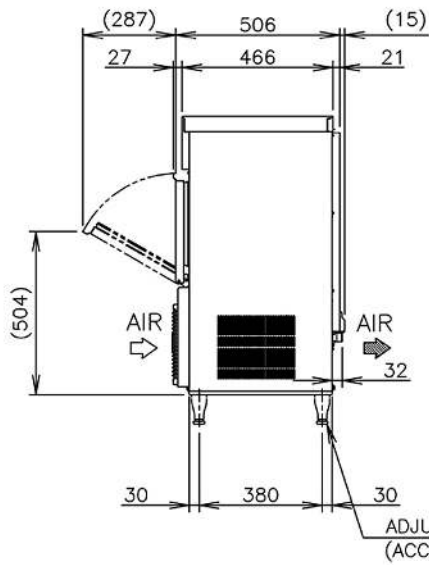
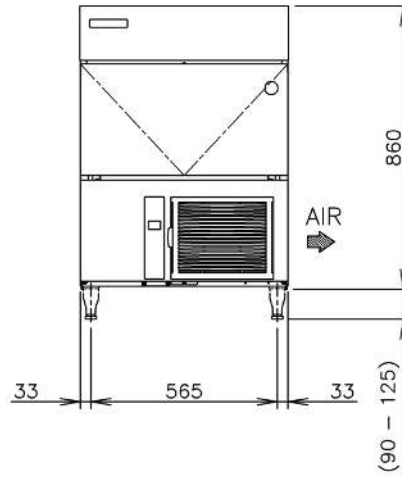
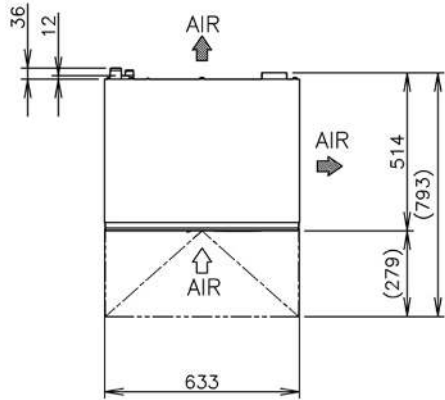

FLAKE ICE - FM SERIES

FM PRODUCT HIGHLIGHTS

The FM series produce flake/nugget ice, with the nugget ice compressed during production to make it long-lasting. The flake and nugget ice is popular for a variety of cooling purposes including the display of fish and fresh produce, and also in the medical world for cooling blood and organs.



The characteristics of the ice produced by Hoshizaki ice makers means that 'freeze-burn' is no longer an issue when displaying fresh fish or produce.

Carbon Auger bearings are used within this range and they are far more robust than roller bearings, enhancing product life expectancy and also reducing maintenance costs.



Flake



Nugget



Cubelet Ice

FM-150KE SERIES



WaterMark

ATS 5200.105
22349, 22350, 22351



Product Specifications

COOLING	Air
WEIGHT	Net: 71kg Packed: 82kg
AC SUPPLY VOLTAGE	220 - 240V / 50Hz 10Amps
REFRIGERANT	R134a
AMBIENT	5°C - 40°C
WATER TEMP	5°C - 30°C
WATER PRESSURE	50 - 800kPa
FM-150KE ICE PRODUCTION PER 24 HOURS (APPROX)	Air Temp: 10°C Water temp: 10°C - 150kg Air Temp: 21°C Water temp: 15°C - 130kg Air Temp: 32°C Water temp: 21°C - 110kg
FM-150KE-N ICE PRODUCTION PER 24 HOURS (APPROX)	Air temp: 10°C Water temp: 10°C - 140kg Air temp: 21°C Water temp: 15°C - 120kg Air temp: 32°C Water temp: 21°C - 100kg
MAX STORAGE CAPACITY	FM-150KE: 26kg FM-150KE-N: 32kg
BIN CONTROL	FM-150KE: 21kg FM-150KE-N: 27kg

Product Range

PART NO.	DESCRIPTION	LIST PRICE
91000101	FM-150KE	



FM-150KE SERIES

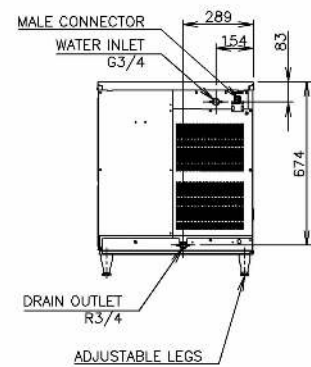
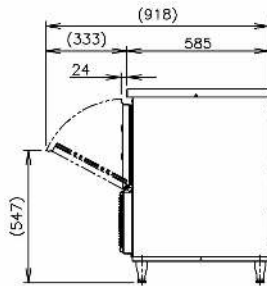
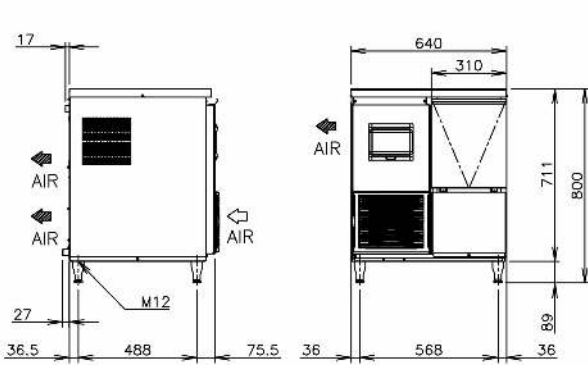
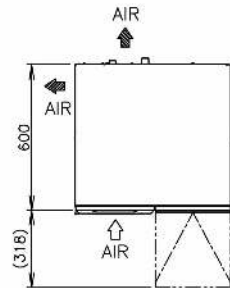

FM-480AKE SERIES



WaterMark

ATS 5200.105
22349, 22350, 22351



FM-480AKE+B-3015A



Product Specifications

COOLING	Air
WEIGHT	Net: 95kg Packed: 102kg
AC SUPPLY VOLTAGE	220 - 240V / 50Hz 15Amps
REFRIGERANT	R404A
AMBIENT	5 - 40°C
WATER TEMP	5 - 35°C
WATER PRESSURE	50 - 800kPa
FM-480AKE ICE PRODUCTION PER 24 HOURS (APPROX)	Air temp: 10°C Water temp: 10°C - 500kg Air temp: 21°C Water temp: 15°C - 452kg Air temp: 32°C Water temp: 21°C - 325kg
FM-480AKE-N ICE PRODUCTION PER 24 HOURS (APPROX)	Air temp: 10°C Water temp: 10°C - 430kg Air temp: 21°C Water temp: 15°C - 360kg Air temp: 32°C Water temp: 21°C - 290kg

Product Range

PART NO.	DESCRIPTION	LIST PRICE
91000104	FM-480AKE	



FM-480AKE SERIES

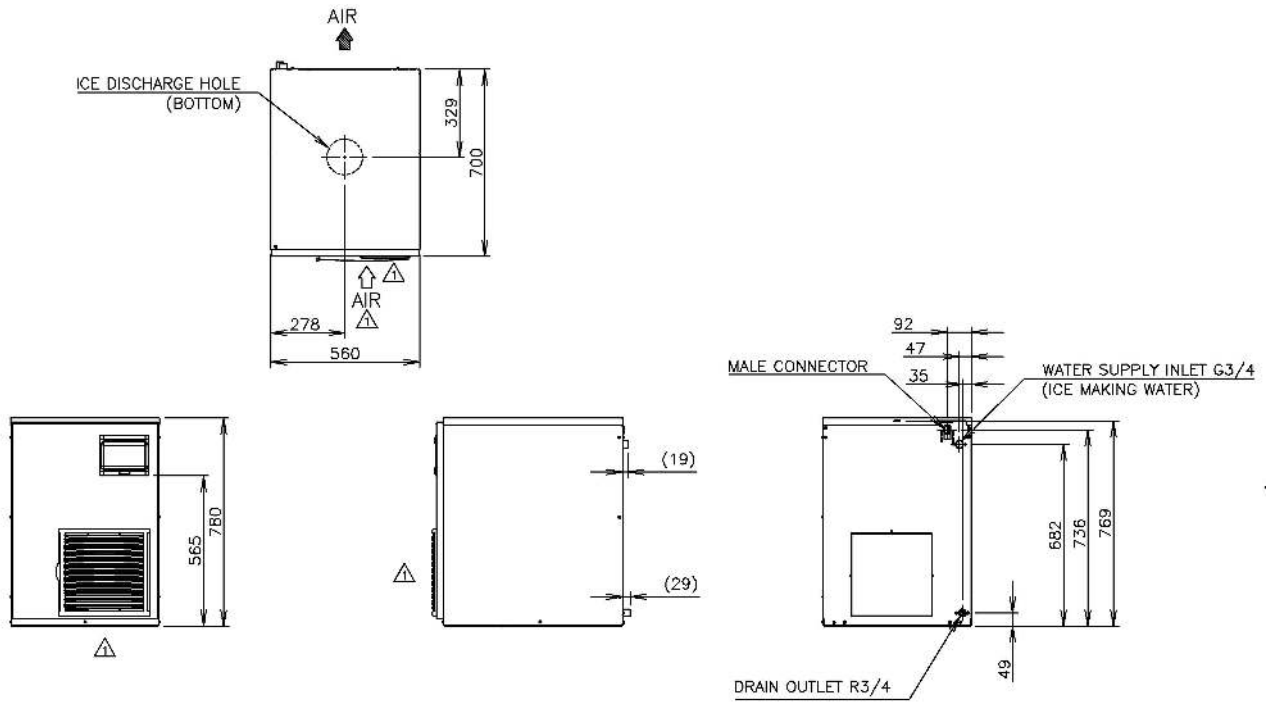

FM-750AKE SERIES



WaterMark

ATS 5200.105
22349, 22350, 22351



FM-750AKE+B-S015A



Product Specifications

COOLING	Air
WEIGHT	Net: 133kg Packed: 143kg
AC SUPPLY VOLTAGE	220 - 240V / 50Hz 15Amps
REFRIGERANT	R404A
AMBIENT	5 - 40°C
WATER TEMP	5 - 35°C
WATER PRESSURE	50 - 800kPa
FM-750AKE ICE PRODUCTION PER 24 HOURS (APPROX)	Air temp: 10°C Water temp: 10°C - 750kg Air temp: 21°C Water temp: 15°C - 650kg Air temp: 32°C Water temp: 21°C - 100kg
FM-750AKE-N ICE PRODUCTION PER 24 HOURS (APPROX)	Air temp: 10°C Water temp: 10°C - 140kg Air temp: 21°C Water temp: 15°C - 120kg Air temp: 32°C Water temp: 21°C - 390kg

Product Range

PART NO.	DESCRIPTION	LIST PRICE
91000080	FM-750AKE	



FM-750AKE SERIES

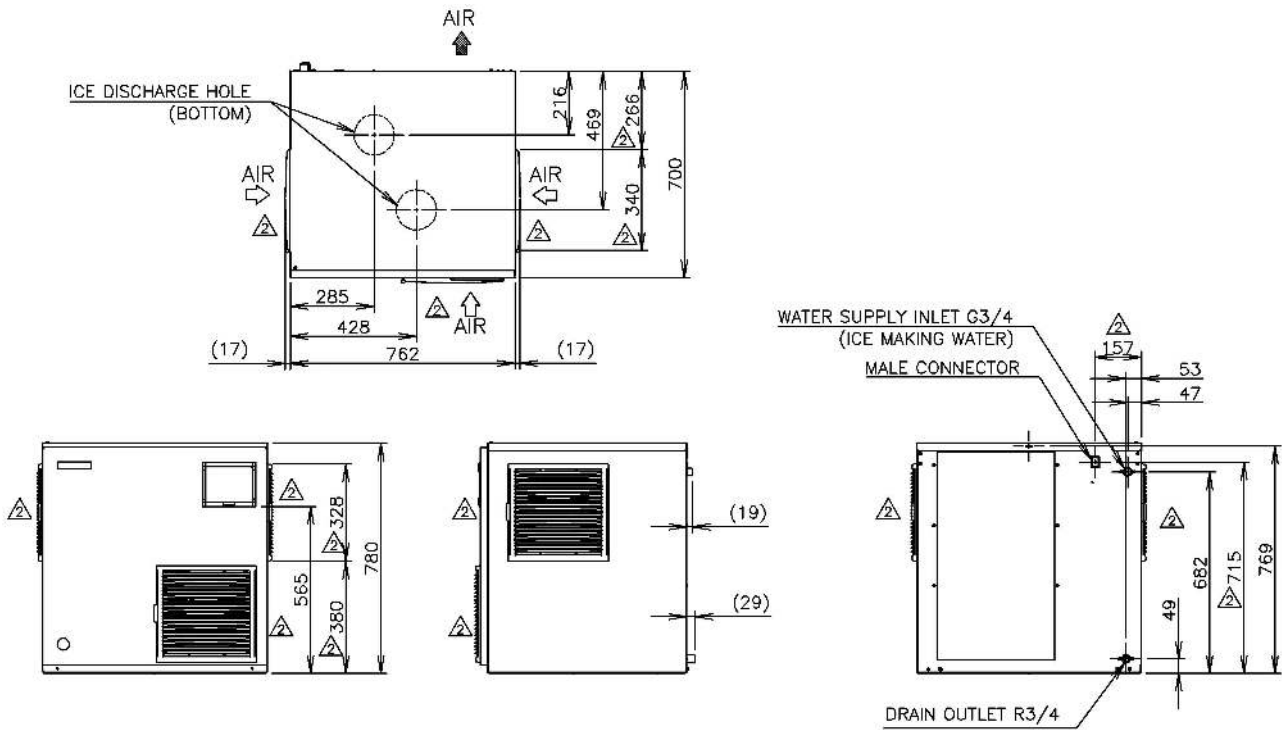

FM-1000AKE SERIES



WaterMark

ATS 5200.105
22349, 22350, 22351



FM-1000AKE + B-501SA



Product Specifications

COOLING	Air
WEIGHT	Net: 146kg Packed: 156kg
AC SUPPLY VOLTAGE	220 - 240V / 50Hz 15Amps
REFRIGERANT	R404A
AMBIENT	5 - 40°C
WATER TEMP	5 - 35°C
WATER PRESSURE	50 - 800kPa
FM-1000AKE ICE PRODUCTION PER 24 HOURS (APPROX)	Air temp: 10°C Water temp: 10°C - 1030kg Air temp: 21°C Water temp: 15°C - 890kg Air temp: 32°C Water temp: 21°C - 740kg
FM-1000AKE-N ICE PRODUCTION PER 24 HOURS (APPROX)	Air temp: 10°C Water temp: 10°C - 860kg Air temp: 21°C Water temp: 15°C - 730kg Air temp: 32°C Water temp: 21°C - 590kg

Product Range

PART NO.	DESCRIPTION	LIST PRICE
91000081	FM-1000AKE (N)	



FM-1000AKE SERIES

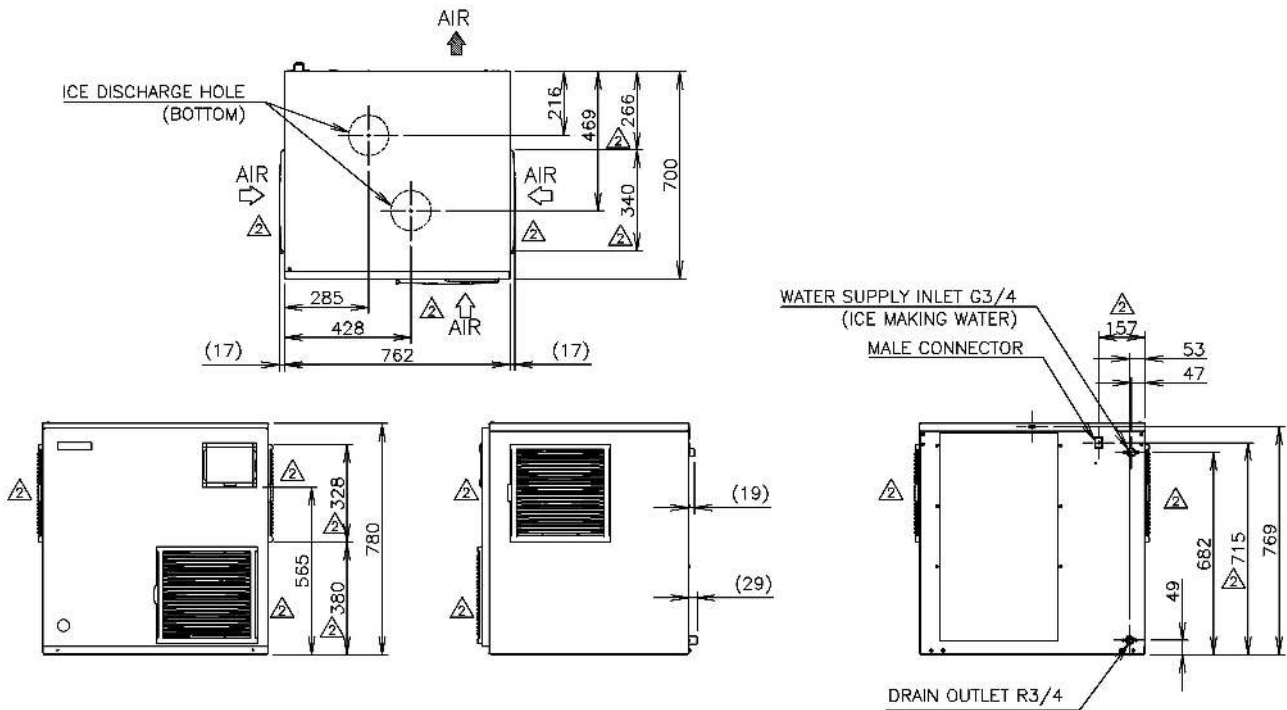

CRESCENT ICE - KM SERIES

KM PRODUCT HIGHLIGHTS



KM machines produce clear, crescent shaped ice. The unique shape is extremely versatile and extends from the splash-free serving of post mix soft drinks through to diverse applications such as fish transportation, display and even laser therapy.



This range includes a double-sided stainless steel evaporator, which requires fewer cycles to produce a full bin of ice, thereby reducing energy consumption.



All units are easily accessible for service via the front of unit. This reduces the time it takes to complete maintenance costs.



Ice machines are computer controlled so the ice making process is optimised under varying circumstances without the need for physical adjustments.



An easily cleanable air filter allows users to carry out a routine cleaning schedule themselves, extending the life expectancy of the ice maker, and cutting the frequency and cost of maintenance call-outs.

KM-30A



WaterMark

ATS 5200.105
22349, 22350, 22351



CRESCENT ICE

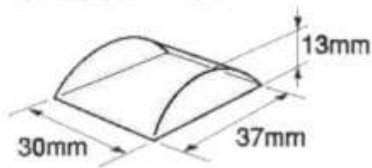

Product Specifications

COOLING	Air
WEIGHT	Net: 39kg Packed: 49kg
AC SUPPLY VOLTAGE	220 - 240V / 50Hz 10Amps
REFRIGERANT	R134a
AMBIENT	1°C - 40°C
WATER TEMP	5°C - 30°C
WATER PRESSURE	70 - 800kPa
ICE PRODUCTION PER 24 HOURS (APPROX)	Air temp: 10°C Water temp: 10°C - 36kg Air temp: 21°C Water temp: 15°C - 32kg Air temp: 32°C Water temp: 21°C - 25kg
ICE PRODUCTION PER CYCLE	0.71kg / 80pcs
FREEZE CYCLE	30mins
MAX STORAGE CAPACITY	16kg

Product Range

PART NO.	DESCRIPTION	LIST PRICE
91000030	KM-30A	
91000031	KM-50A	
91000032	KM-75A	



KM-30A

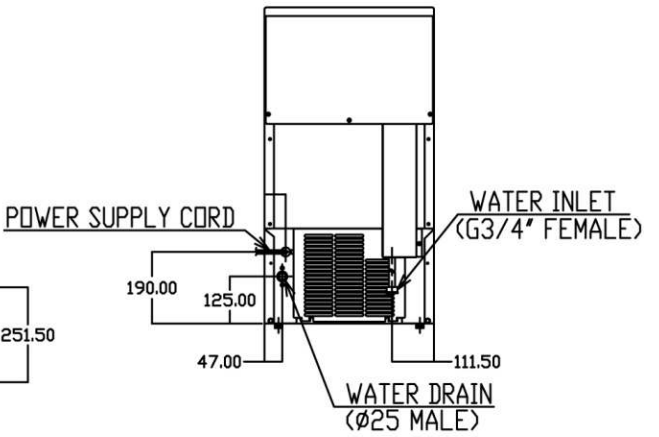
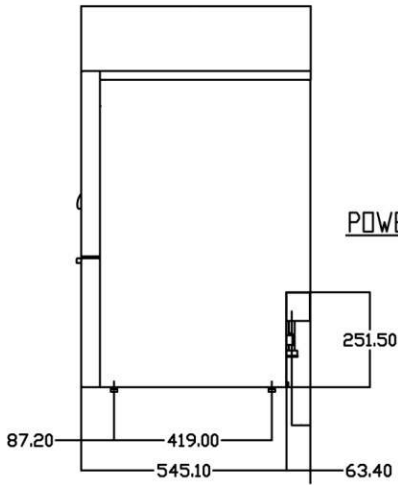
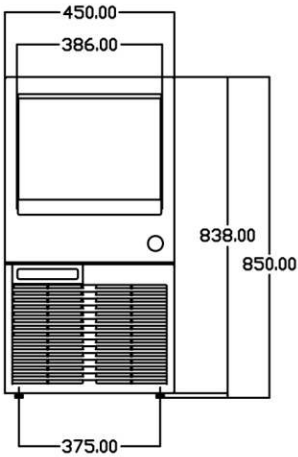
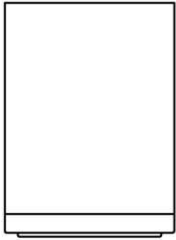

KM-50A



WaterMark

ATS 5200.105
22349, 22350, 22351



CRESCENT ICE



Product Specifications

COOLING	Air
WEIGHT	Net: 46kg Packed: 58kg
AC SUPPLY VOLTAGE	220 - 240V /50Hz 10Amps
REFRIGERANT	R134a
AMBIENT	1°C - 40°C
WATER TEMP	5°C - 35°C
WATER PRESSURE	70 - 800kPa
ICE PRODUCTION PER 24 HOURS (APPROX)	Air temp: 10°C Water temp: 10°C - 52kg Air temp: 21°C Water temp: 15°C - 50kg Air temp: 32°C Water temp: 21°C - 41kg
ICE PRODUCTION PER CYCLE	0.95kg / 110pcs
FREEZE CYCLE	25mins
MAX STORAGE CAPACITY	23kg

Product Range

PART NO.	DESCRIPTION	LIST PRICE
91000030	KM-30A	
91000031	KM-50A	
91000032	KM-75A	



KM-50A

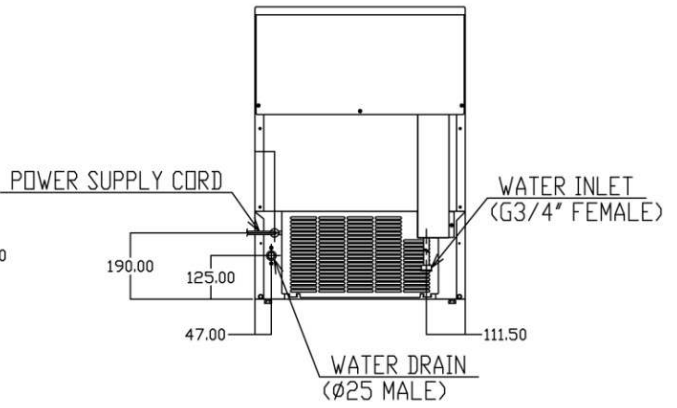
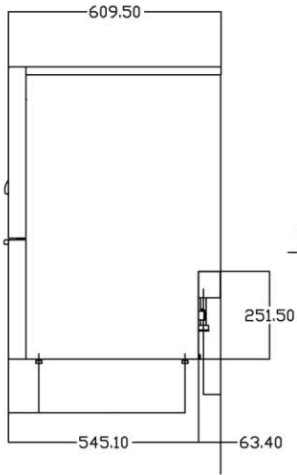
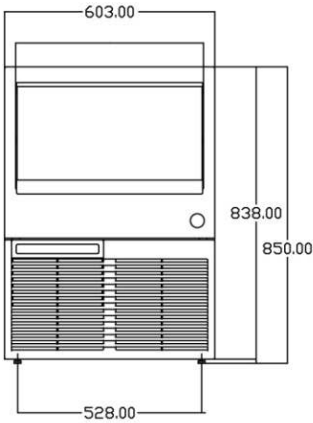
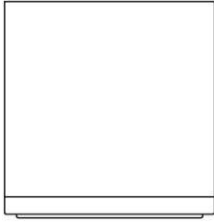

KM-75A



WaterMark

ATS 5200.105
22349, 22350, 22351



CRESCENT ICE

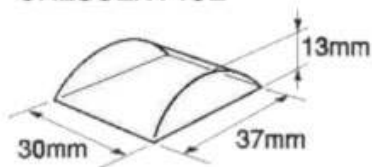

Product Specifications

COOLING	Air
WEIGHT	Net: 51kg Packed: 64kg
AC SUPPLY VOLTAGE	220 - 240V / 50Hz 10Amps
REFRIGERANT	R134a
AMBIENT	1°C - 40°C
WATER TEMP	5°C - 35°C
WATER PRESSURE	70 - 800kPa
ICE PRODUCTION PER 24 HOURS (APPROX)	Air temp: 10°C Water temp: 10°C - 72kg Air temp: 21°C Water temp: 15°C - 70kg Air temp: 32°C Water temp: 21°C - 55kg
ICE PRODUCTION PER CYCLE	1.25kg / 130pcs
FREEZE CYCLE	24mins
MAX STORAGE CAPACITY	40kg

Product Range

PART NO.	DESCRIPTION	LIST PRICE
91000030	KM-30A	
91000031	KM-50A	
91000032	KM-75A	



KM-75A

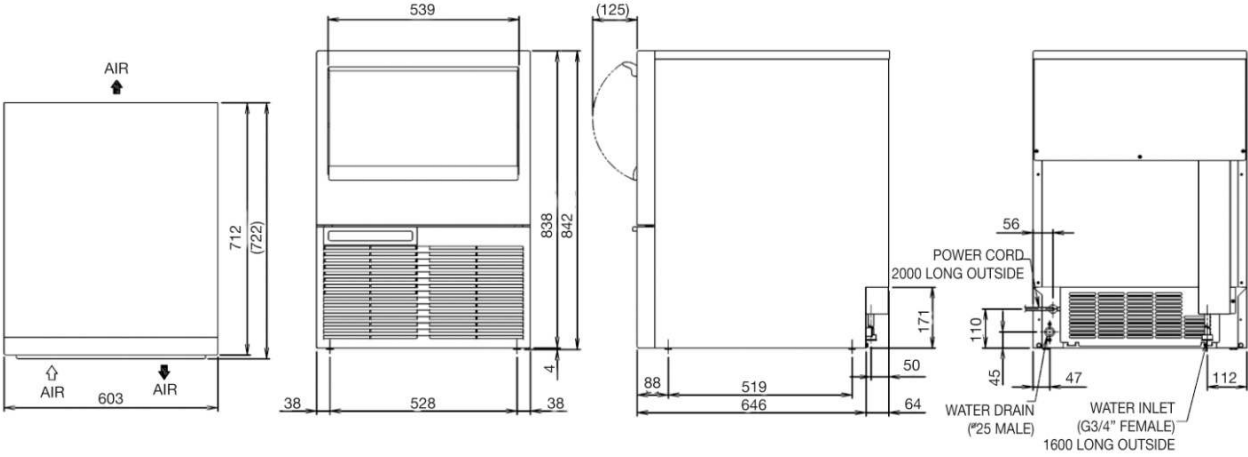

KM-100A



WaterMark

ATS 5200.105
22349, 22350, 22351



CRESCENT ICE

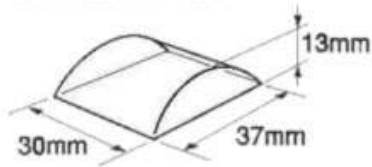

Product Specifications

COOLING	Air
WEIGHT	Net: 62kg Packed: 75kg
AC SUPPLY VOLTAGE	220 - 240V / 50Hz 10Amps
REFRIGERANT	R404A
AMBIENT	1°C - 40°C
WATER TEMP	5°C - 35°C
WATER PRESSURE	50 - 800kPa
ICE PRODUCTION PER 24 HOURS (APPROX)	Air temp: 10°C Water Temp: 10°C - 101kg Air temp: 21°C Water Temp: 15°C - 88kg Air temp: 32°C Water Temp: 21°C - 64kg
ICE PRODUCTION PER CYCLE	1.7kg / 182pcs
FREEZE CYCLE	26mins
MAXIMUM STORAGE CAPACITY	45kg

Product Range

PART NO.	DESCRIPTION	LIST PRICE
91000055	KM-100A	
91000056	KM-125A	



KM-100A

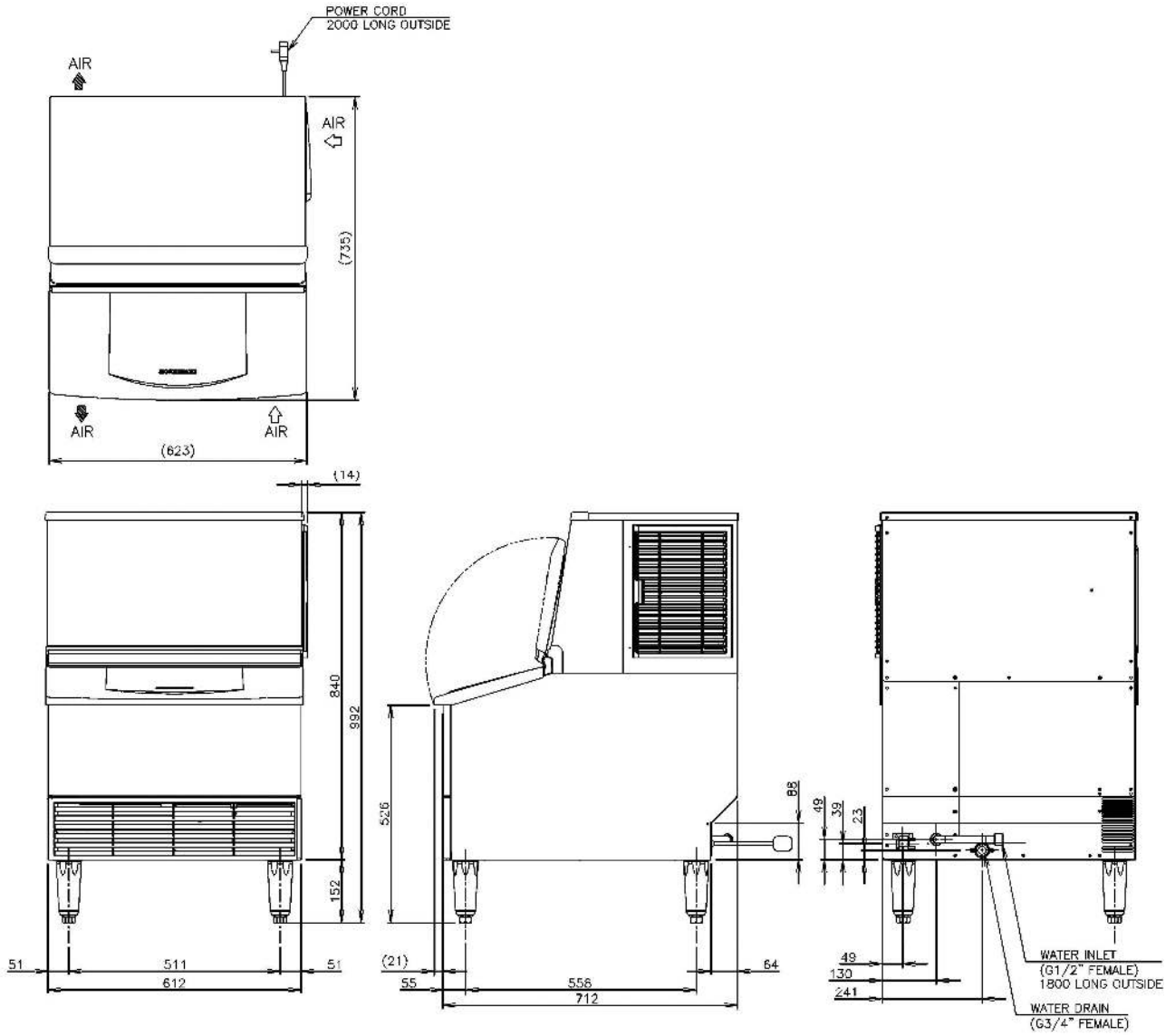

KM-125A



WaterMark

ATS 5200.105
22349, 22350, 22351



CRESCENT ICE



Product Specifications

COOLING	Air
WEIGHT	Net: 70kg Packed: 85kg
AC SUPPLY VOLTAGE	220 - 240V / 50Hz 10Amps
REFRIGERANT	R404A
AMBIENT	1°C - 40°C
WATER TEMP	5°C - 35°C
WATER PRESSURE	50 - 800kPa
ICE PRODUCTION PER 24 HOURS (APPROX)	Air temp: 10°C Water Temp: 10°C - 128kg Air temp: 21°C Water Temp: 15°C - 115kg Air temp: 32°C Water Temp: 21°C - 102kg
ICE PRODUCTION PER CYCLE	2.1kg / 238pcs
FREEZE CYCLE	24mins
MAXIMUM STORAGE CAPACITY	55kg

Product Range

PART NO.	DESCRIPTION	LIST PRICE
91000055	KM-100A	
91000056	KM-125A	



KM-125A

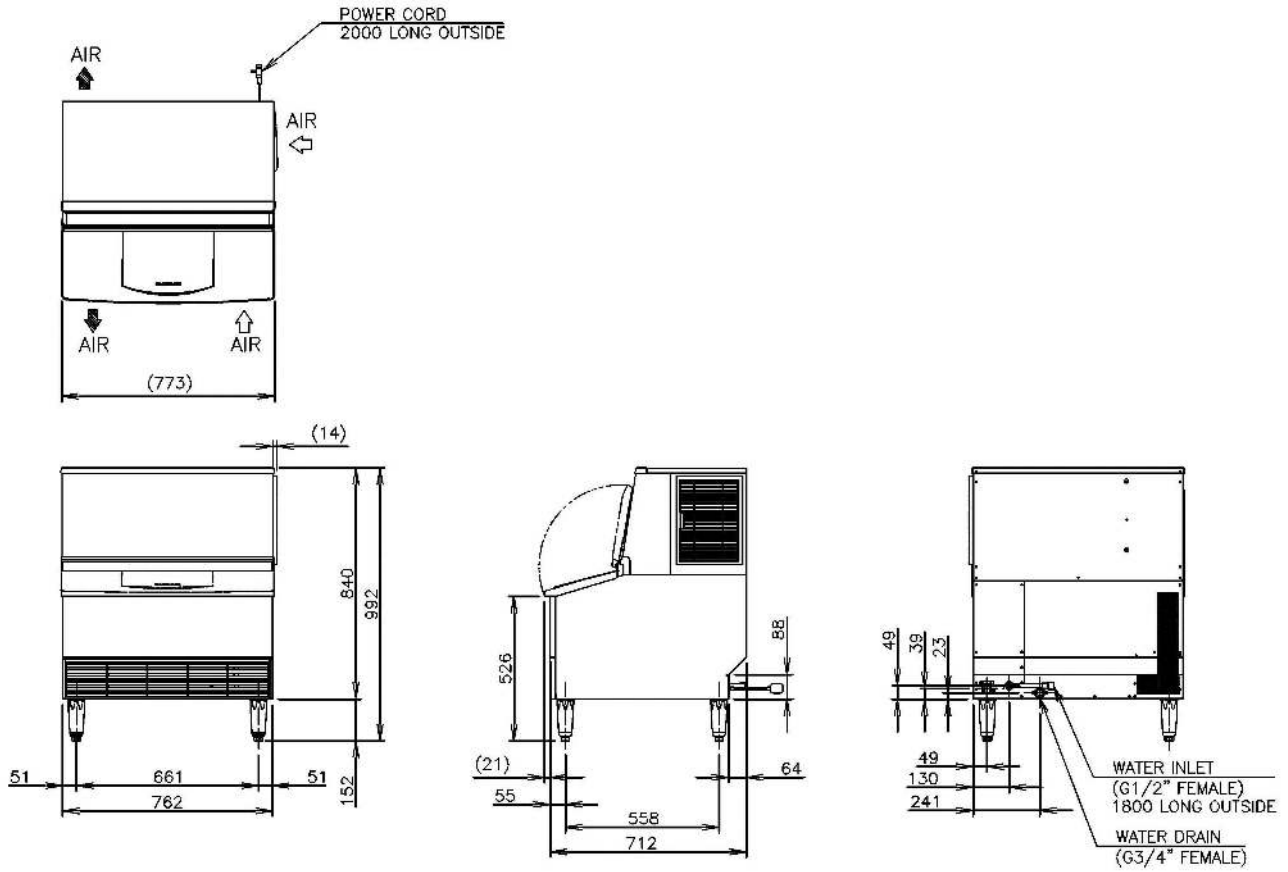

KMD-201AA



WaterMark

ATS 5200.105
22349, 22350, 22351



CRESCENT ICE



Allows installation on 560mm
(22") wide drink dispenser

Product Specifications

COOLING	Air
WEIGHT	Net: 57kg Packed: 73kg
AC SUPPLY VOLTAGE	220 - 240V / 50Hz 10Amps
REFRIGERANT	R404A
AMBIENT	1 - 40°C
WATER TEMP	5 - 35°C
WATER PRESSURE	70 - 800kPa
ICE PRODUCTION PER 24 HOURS (APPROX)	Air temp: 10°C Water temp: 10°C - 205kg Air temp: 21°C Water temp: 15°C - 182kg Air temp: 32°C Water temp: 21°C - 157kg
ICE PRODUCTION PER CYCLE	3.8kg / 416pcs
FREEZE CYCLE	27mins
MAX STORAGE CAPACITY	Select Bin

Product Range

PART NO.	DESCRIPTION	LIST PRICE
91000067	KMD-201AA	



KMD-201AA

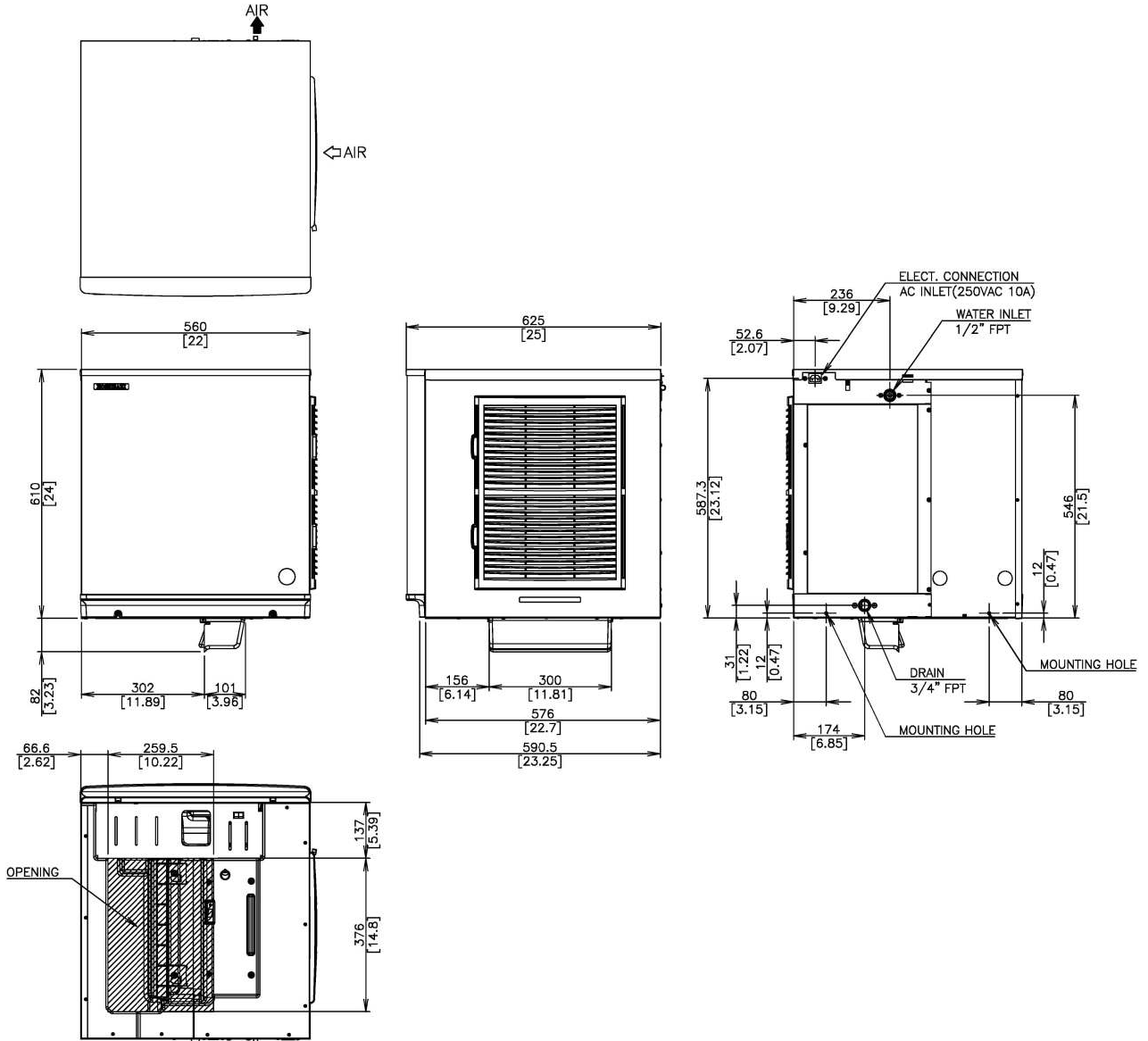

KMD-270AA



WaterMark

ATS 5200.105
22349, 22350, 22351



CRESCENT ICE

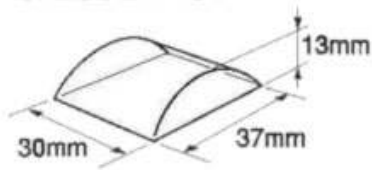

Product Specifications

COOLING	Air
WEIGHT	Net: 57kg Packed: 73kg
AC SUPPLY VOLTAGE	220 - 240V / 50Hz 10Amps
REFRIGERANT	R404A
AMBIENT	1 - 40°C
WATER TEMP	5 - 35°C
WATER PRESSURE	70 - 800kPa
ICE PRODUCTION PER 24 HOURS (APPROX)	Air temp: 10°C Water temp: 10°C - 265kg Air temp: 21°C Water temp: 15°C - 248kg Air temp: 32°C Water temp: 21°C - 221kg
ICE PRODUCTION PER CYCLE	5.7kg / 624pcs
FREEZE CYCLE	27mins
MAX STORAGE CAPACITY	Select Bin

Product Range

PART NO.	DESCRIPTION	LIST PRICE
91000111	KMD-270AA	



KMD-270AA

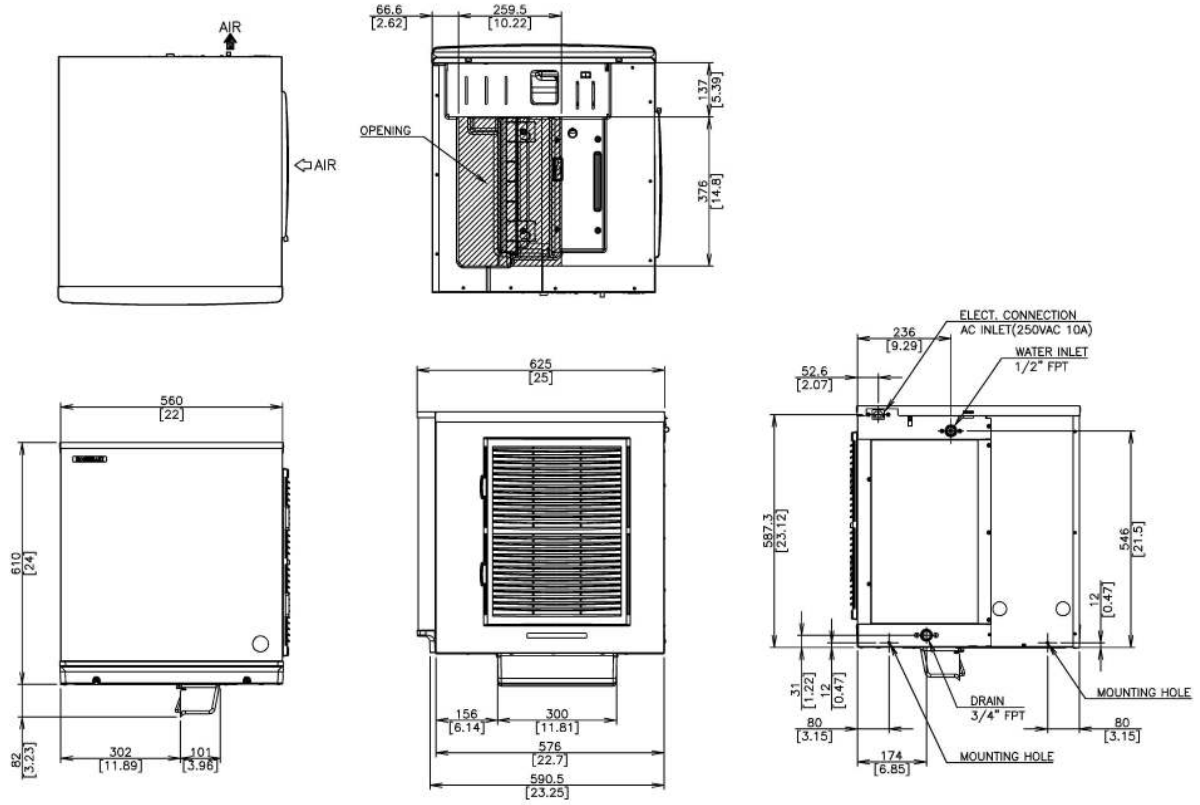

KM-650MAH



WaterMark

ATS 5200.105
22349, 22350, 22351



KM-650MAH + B-301SA

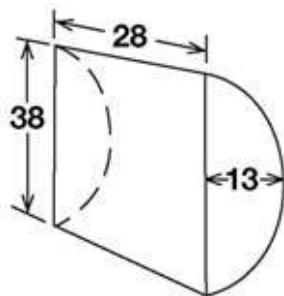

Product Specifications

COOLING	Air
WEIGHT	Net: 77kg Packed: 91kg
AC SUPPLY VOLTAGE	220 - 240V / 50Hz 10Amps
REFRIGERANT	R404A
AMBIENT	7°C - 38°C
WATER TEMP	7°C - 32°C
WATER PRESSURE	68kpaG - 780kpaG
ICE PRODUCTION PER 24 HOURS (APPROX)	Air temp: 10°C Water temp: 10°C - 333kg Air temp: 21°C Water temp: 15°C - 274kg Air temp: 32°C Water temp: 21°C - 243kg
ICE PRODUCTION PER CYCLE	6.4kg / 720pcs
MAXIMUM STORAGE CAPACITY	Select storage bin

Product Range

PART NO.	DESCRIPTION	LIST PRICE
91000016	KM-650MAH	
91000120	KM-901MAH-E	
91000018	KM-1301SAH	



KM-650MAH

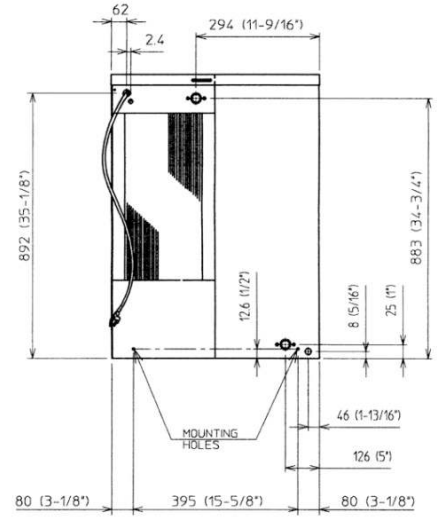
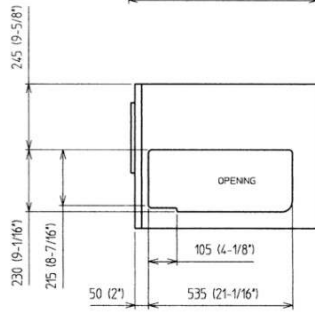
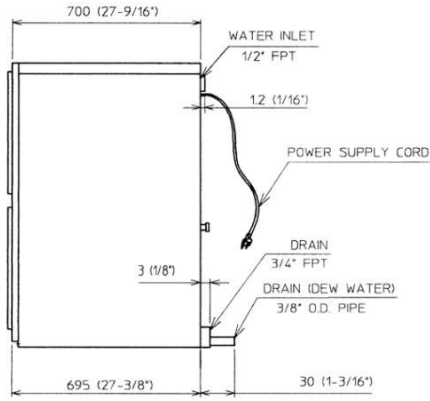
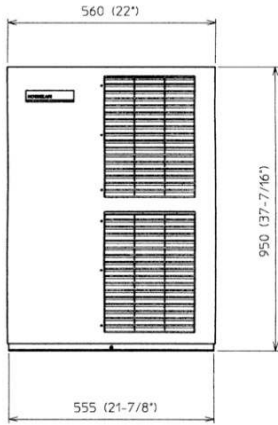

KM-901MAH-E



WaterMark

ATS 5200.105
22349, 22350, 22351



KM-900MAH + B-501SA

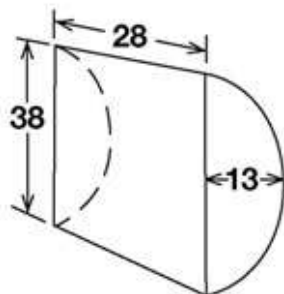

Product Specifications

COOLING	Air
WEIGHT	Net: 98kg Packed: 128kg
AC SUPPLY VOLTAGE	220 - 240V / 50Hz 15Amps
REFRIGERANT	R404A
AMBIENT	7°C - 38°C
WATER TEMP	7°C - 32°C
WATER PRESSURE	68kpaG - 780kpaG
ICE PRODUCTION PER 24 HOURS (APPROX)	Air temp: 10°C Water temp: 10°C - 429kg Air temp: 20°C Water temp: 15°C - 392kg Air temp: 30°C Water temp: 25°C - 321kg
ICE PRODUCTION PER CYCLE	6.5kg/720pcs
MAX STORAGE CAPACTIY	Select storage bin

Product Range

PART NO.	DESCRIPTION	LIST PRICE
91000016	KM-650MAH	
91000120	KM-901MAH-E	
91000018	KM-1301SAH	



KM-901MAH-E

FRONT VIEW

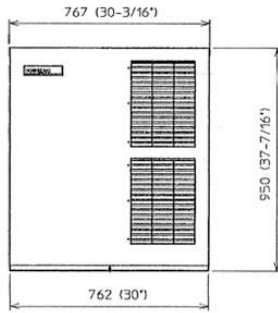

SIDE VIEW

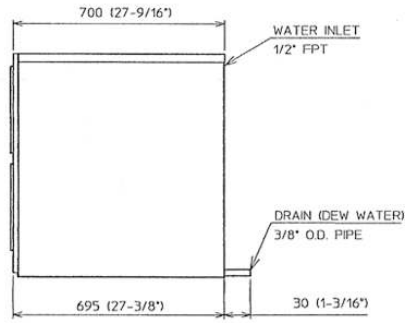

BACK VIEW

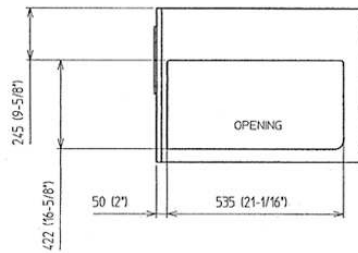
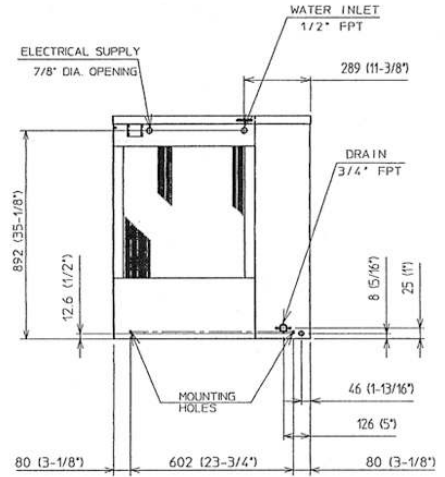

KM-1301SAH



WaterMark

ATS 5200.105
22349, 22350, 22351



KM-1301SAH + B-801SA

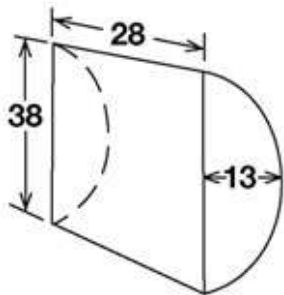

Product Specifications

COOLING	Air
WEIGHT	Net: 120kg Packed: 143kg
AC SUPPLY VOLTAGE	220 - 240V / 50Hz 15Amps
REFRIGERANT	R404A
AMBIENT	1 - 40°C
WATER TEMP	5 - 35°C
WATER PRESSURE	50 - 800kPa
ICE PRODUCTION PER 24 HOURS (APPROX)	Air temp: 10°C Water Temp: 10°C - 584kg Air temp: 21°C Water Temp: 15°C - 522kg Air temp: 32°C Water Temp: 21°C - 465kg
ICE PRODUCTION PER CYCLE	13.2kg / 1440pcs
FREEZE CYCLE	35mins
MAX STORAGE CAPACITY	Select Bin

Product Range

PART NO.	DESCRIPTION	LIST PRICE
91000018	KM-1301SAH	



KM-1301SAH

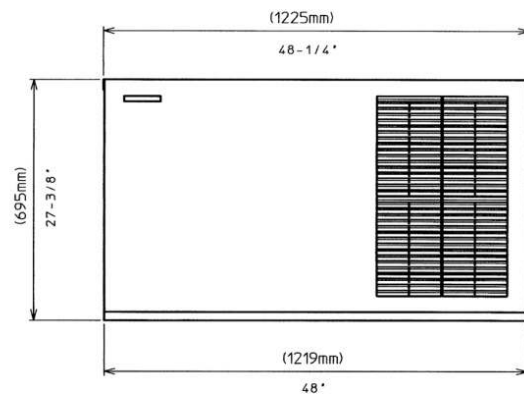
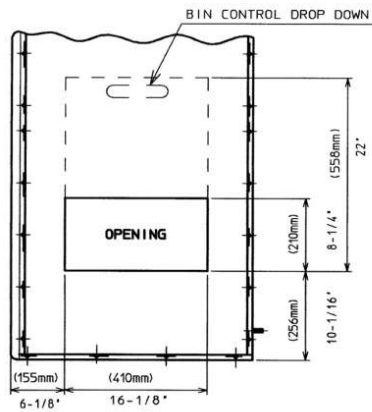
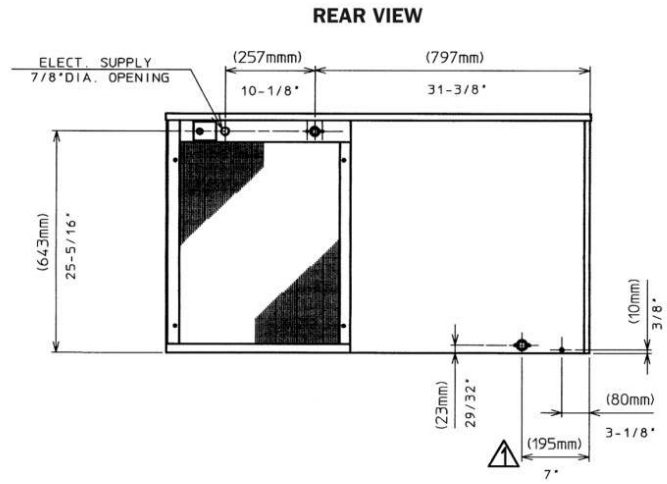
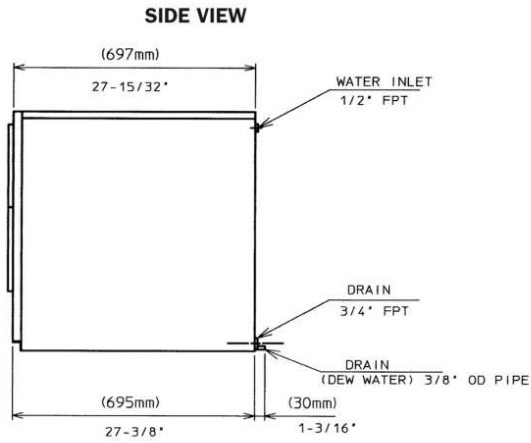

BOTTOM VIEW

FRONT VIEW

CUBELET ICE - DISPENSER SERIES

PRODUCT HIGHLIGHTS



The New DCM-60KE



DIM-30DE

- Ice and/or water mix at the touch of a button, making it as easy and simple to use as possible and therefore ideal for self-service environments.
- Portion control can be easily set, making it easy to regulate the consumption of ice among end-users, reducing energy consumption and waste.
- Due to the auger system the water consumption is equal to the ice production.
- Ice is dispensed directly into the cup or bucket reducing the risk of contamination.

DCM-60KE-P ICE & WATER DISPENSER



WaterMark

ATS 5200.105
22349, 22350, 22351



Product Specifications

Cooling	Air
Weight	Net: 47kg Packed: 56kg
AC Supply Voltage	220 - 240V / 50Hz 10Amps
Refrigerant	R134a
Ambient	5 - 40°C
Water temp	5 - 35°C
Water pressure	50 - 780kPa
Ice production per 24 hours (approx)	Air temp: 10°C Water temp: 10°C - 60kg Air temp: 21°C Water temp: 15°C - 50kg Air temp: 32°C Water temp: 21°C - 38kg
Max Storage Capacity	1.9kg

Product Range

PART NO.	DESCRIPTION	LIST PRICE
91000116	DCM-60KE-P	
91000115	DCM-120KE-P	



DCM-60KE-P ICE & WATER DISPENSER

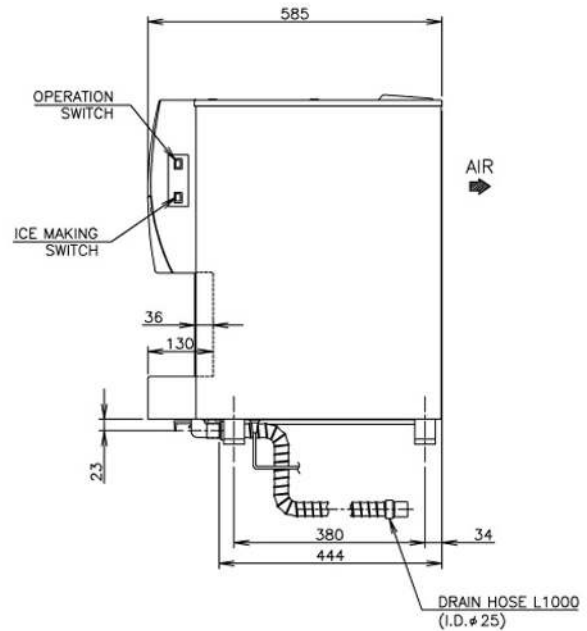
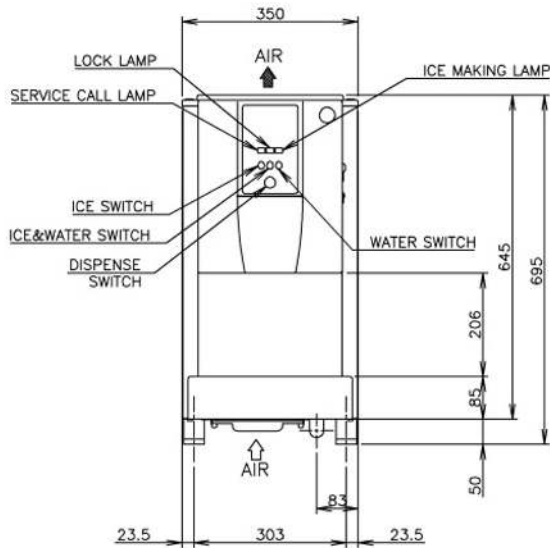
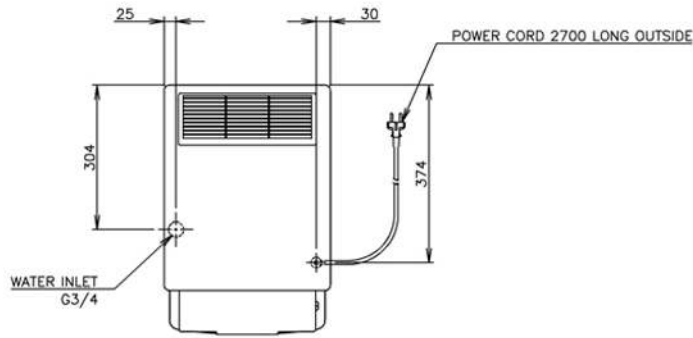

DCM-120KE-P ICE & WATER DISPENSER



WaterMark

ATS 5200.105
22349, 22350, 22351



Product Specifications

Cooling	Air
Weight	Net: 57kg Packed: 66kg
AC Supply Voltage	220 - 240V / 50Hz 10Amps
Refrigerant	R134a
Ambient	5 - 40°C
Water temp	5 - 35°C
water pressure	50 - 780kPa
Ice production per 24 hours (approx)	Air temp: 10°C Water temp: 10°C - 125kg Air temp: 21°C Water temp: 15°C - 105kg Air temp: 32°C Water temp: 21°C - 85kg
Max Storage Capacity	4kg

Product Range

PART NO.	DESCRIPTION	LIST PRICE
91000115	DCM-120KE-P	
91000116	DCM-60KE-P	



DCM-120KE-P ICE & WATER DISPENSER

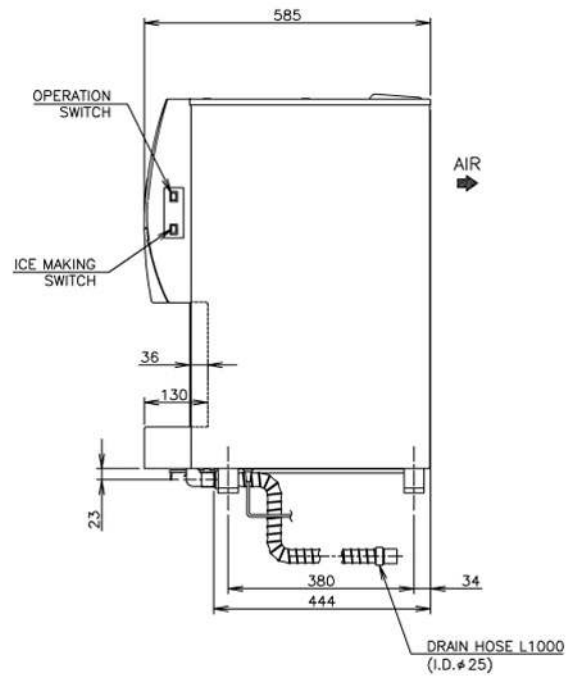
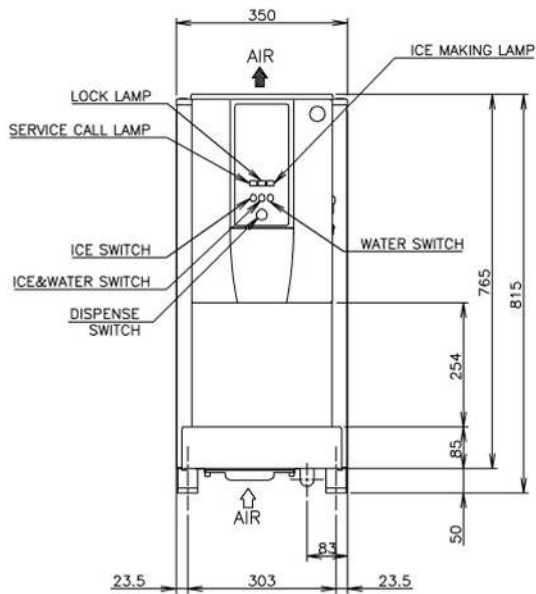
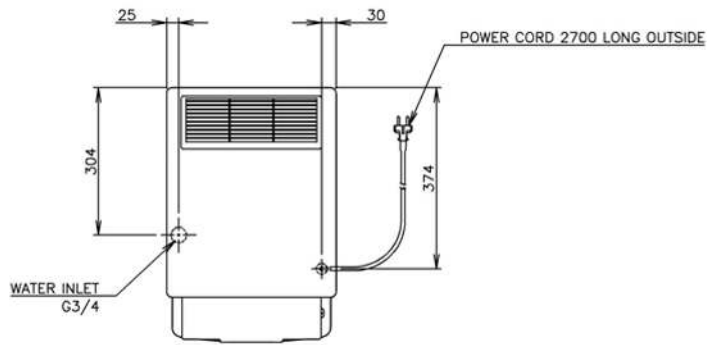

DB-200H SANITARY ICE CUBE DISPENSER



<i>Product Specifications</i>	
<i>Dimensions</i>	Width: 762mm Depth: 757mm Height: 1346mm
<i>Weight</i>	Net: 85kg
<i>GPO capacity</i>	10Amps
<i>Maximum Storage Capacity</i>	91kg

<i>Product Range</i>		
<i>PART NO.</i>	<i>DESCRIPTION</i>	<i>LIST PRICE</i>
9100063	DB200 Dispenser	
9100131	Ice Dispenser DB200H with H2O	



DB-200H SANITARY ICE CUBE DISPENSER

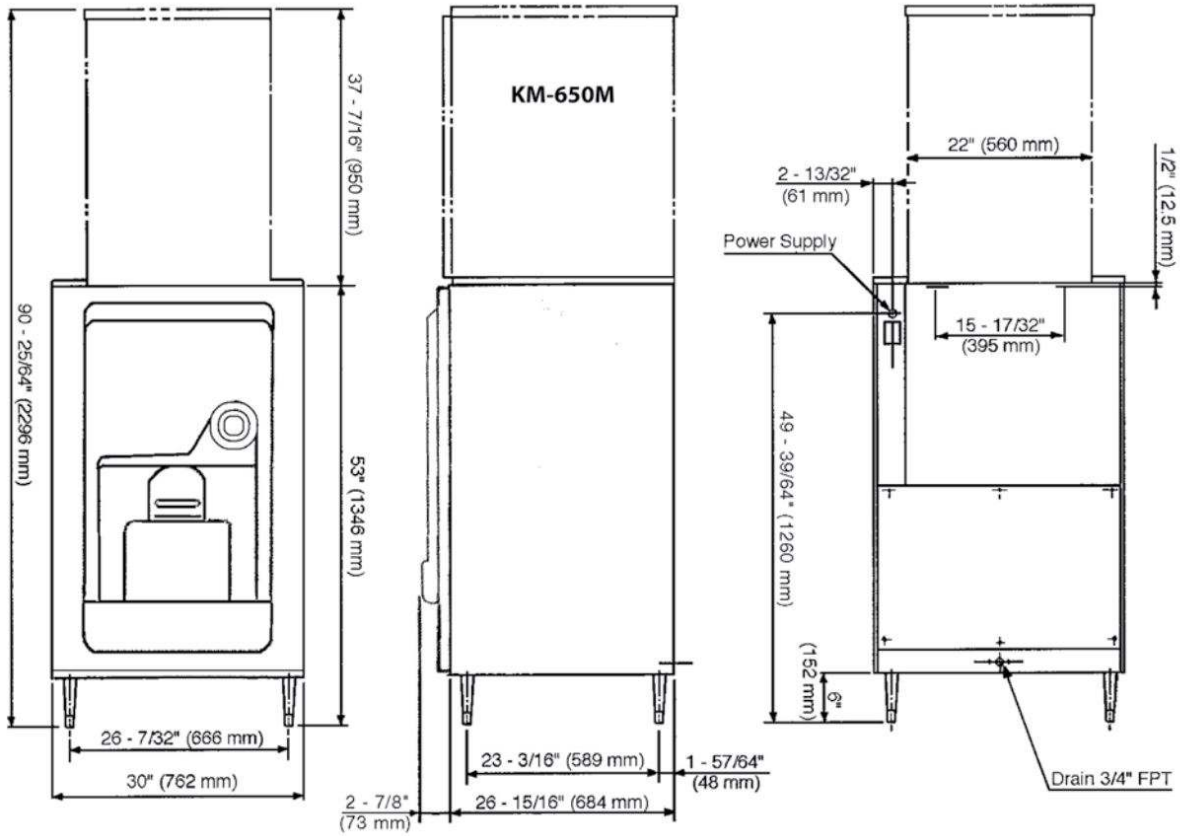

ICE STORAGE BINS & TOP KITS

In order to ensure ample quantities of ice at all times, Hoshizaki offers a wide range of Storage Bins that configure perfectly with Hoshizaki Ice Machines.

The stainless steel exterior provides for easy cleaning and a long lasting attractive appearance.

Sturdy construction for side by side or stacked installations and non-corrosive bin liner provide safe, sanitary storage of cube or flake ice. Foamed in place insulation in all bin walls provides dependable, low melt rate ice storage.

The size of the bins depends on several factors - the capacity of the machine, the average daily demand and the peak demand.



Storage bins, manufactured by Hoshizaki are made of stainless steel and come with legs adjustable between 90 - 120mm.



Bins are easy to clean with round edges for optimal hygiene.

B-301SA



B-301SA

<i>Product Specifications</i>	
<i>BIN CAPACITY</i>	144kg
<i>DIMENSIONS W x D x H (INCL LEGS)</i>	558m x 820mm x 1016mm
<i>WEIGHT (NET)</i>	34kg
<i>TOP KITS: IM240D</i>	N/A
<i>TOP KITS: KM900</i>	N/A
<i>TOP KITS: IM240A, KM650, FM300, FM600</i>	No top kit required
<i>TOP KITS: KMD201, KMD270</i>	No top kit required
<i>TOP KITS: 2 x IM240A, 2 x KM650, 2 x FM300, 2 x FM600</i>	N/A
<i>TOP KITS: 2 x KMD201, 2 x KMD270</i>	N/A
<i>TOP KITS: KM1301, KM2100</i>	N/A
<i>TOP KITS: FM1000, FM1200</i>	N/A
<i>TOP KITS: FM1800</i>	N/A

<i>Product Range</i>		
<i>PART NO.</i>	<i>DESCRIPTION</i>	<i>LIST PRICE</i>
91000025	B-301SA	
91000026	B-501SA	
91000027	B-801SA	
91000053	B-1300SS	
91000054	B-1500SS	

B-301SA

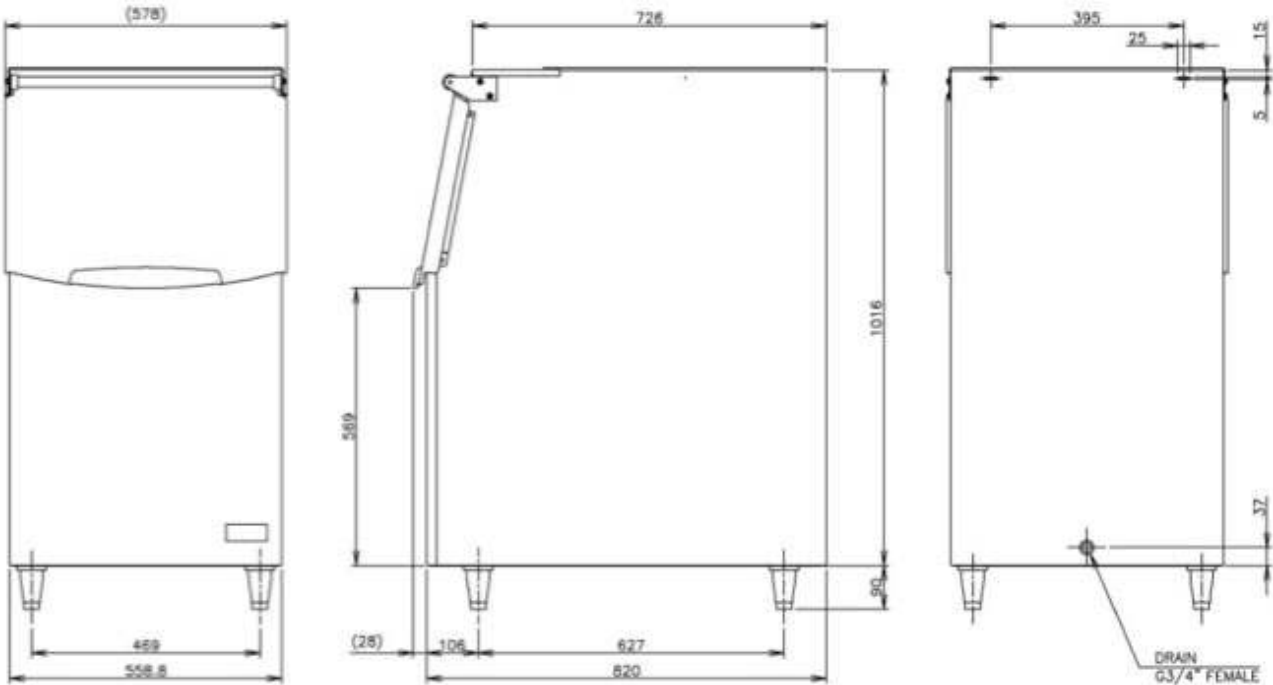

B-501SA



B-501SA

<i>Product Specifications</i>	
<i>BIN CAPACITY</i>	217kg
<i>DIMENSIONS W X D X H (INCL LEGS)</i>	762mm x 820mm x 1016mm
<i>WEIGHT (NET)</i>	47kg
<i>TOP KITS: IM240D</i>	N/A
<i>TOP KITS: KM900</i>	No top kit required
<i>TOP KITS: IM240A, KM650, FM300, FM600</i>	8D
<i>TOP KITS: KMD201, KMD270</i>	8D
<i>TOP KITS: 2 x IM240A, 2 x KM650, 2 x FM300, 2 x FM600</i>	N/A
<i>TOP KITS: 2 x KMD201, 2 x KMD270</i>	N/A
<i>TOP KITS: KM1301, KM2100</i>	N/A
<i>TOP KITS: FM1000, FM1200</i>	No top kit required
<i>TOP KITS: FM1800</i>	N/A

<i>Product Range</i>		
<i>PART NO.</i>	<i>DESCRIPTION</i>	<i>LIST PRICE</i>
91000025	B-301SA	
91000026	B-501SA	
91000027	B-801SA	
91000053	B-1300SS	
91000054	B-1500SS	

B-501SA

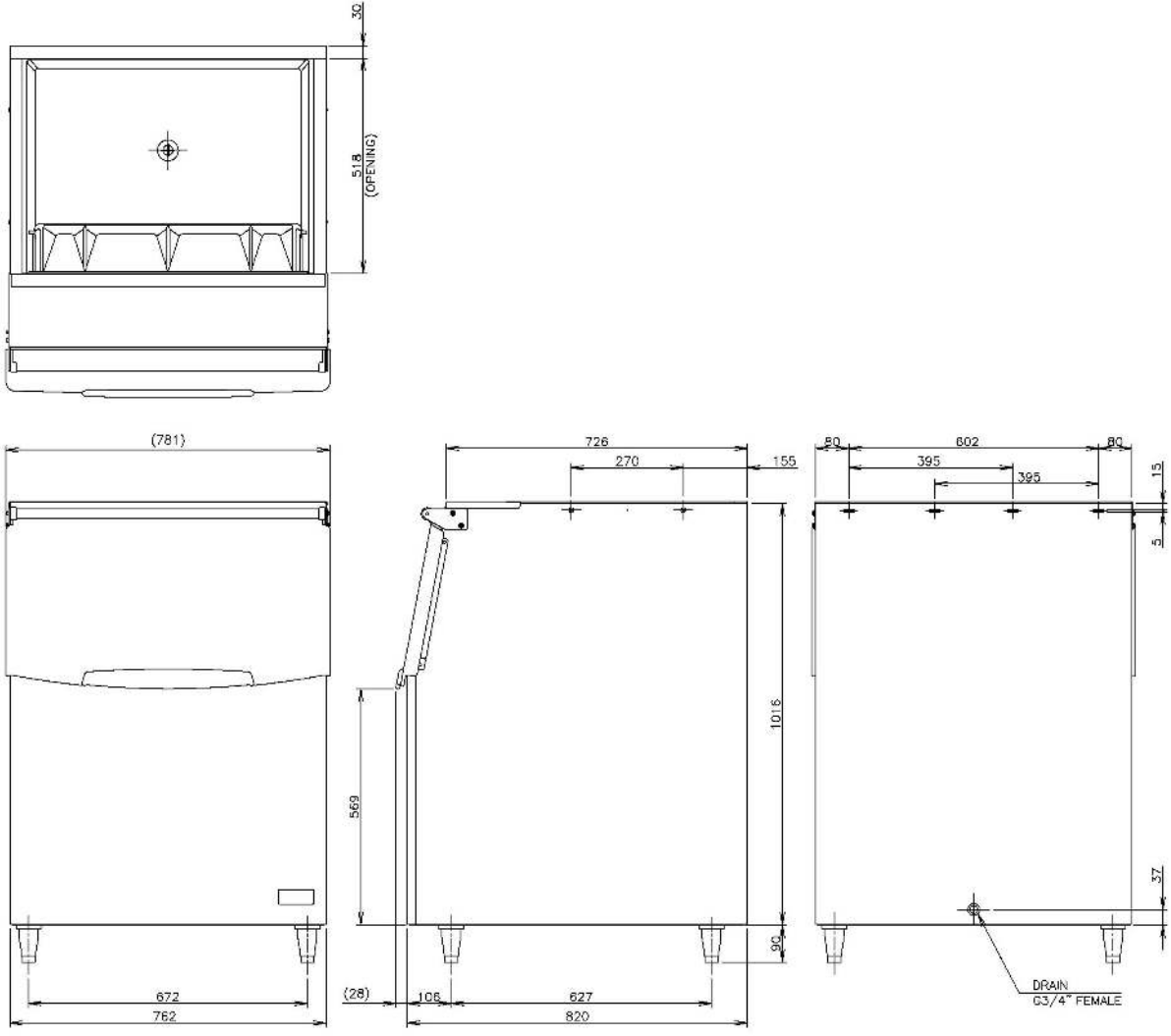

B-801SA



B-801SA

<i>Product Specifications</i>	
<i>BIN CAPACITY</i>	348kg
<i>DIMENSIONS W x D x H (INCL LEGS)</i>	1292mm x 820mm x 1016mm
<i>WEIGHT (NET)</i>	64kg
<i>TOP KITS: IM240D</i>	IMD
<i>TOP KITS: KM900</i>	8D + 18D
<i>TOP KITS: IM240A, KM650, FM300, FM600</i>	8D + 18D
<i>TOP KITS: KMD201, KMD270</i>	8D + 18D
<i>TOP KITS: 2 x IM240A, 2 x KM650, 2 x FM300, 2 x FM600</i>	4DM
<i>TOP KITS: 2 x KMD201, 2 x KMD270</i>	4DM + 4DR Universal
<i>TOP KITS: KM1301, KM2100</i>	No top kit required
<i>TOP KITS: FM1000, FM120</i>	18D
<i>TOP KITS: FM1800</i>	TK-1800

<i>Product Range</i>		
<i>PART NO.</i>	<i>DESCRIPTION</i>	<i>LIST PRICE</i>
91000025	B-301SA	
91000026	B-501SA	
91000027	B-801SA	
91000053	B-1300SS	
91000054	B-1500SS	

B-801SA

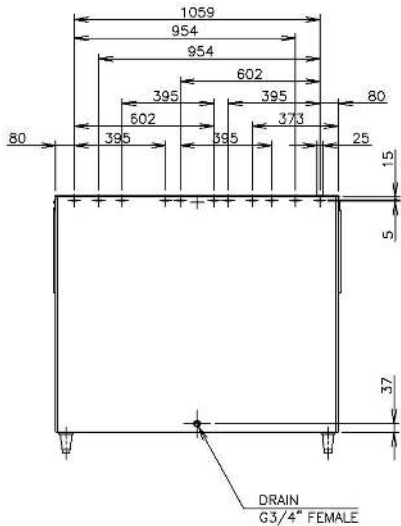
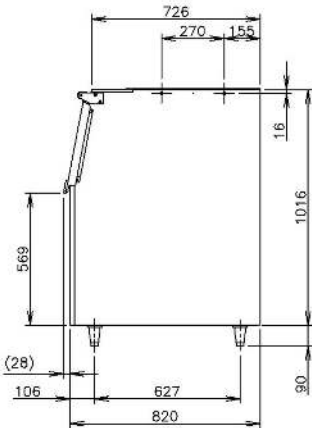
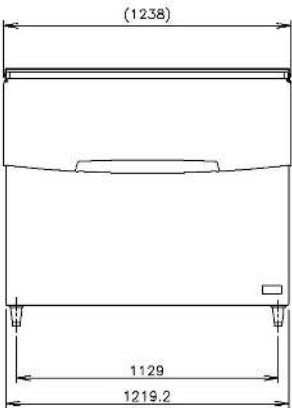
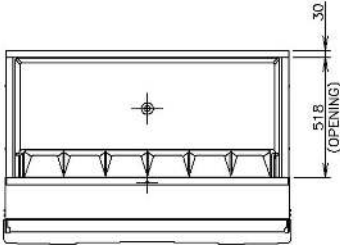

B-1300SS



B-1300SS

<i>Product Specifications</i>	
<i>BIN CAPACITY</i>	578kg
<i>DIMENSIONS W x D x H (INCL LEGS)</i>	1218mm x 1040mm x 1680mm
<i>WEIGHT</i>	140kg
<i>TOP KITS: IM240D</i>	Universal
<i>TOP KITS: KM900</i>	Universal
<i>TOP KITS: IM240A, KM650, FM300, FM600</i>	Universal
<i>TOP KITS: KMD201, KMD270</i>	Universal
<i>TOP KITS: 2 x IM240A, 2 x KM650, 2 x FM300, 2 x FM650</i>	Universal
<i>TOP KITS: 2 x KMD201, 2 x KMD270</i>	Universal
<i>TOP KITS: FM1000, FM1200</i>	Universal
<i>TOP KITS: FM1800</i>	Universal

<i>Product Range</i>		
<i>PART NO.</i>	<i>DESCRIPTION</i>	<i>LIST PRICE</i>
91000025	B-301SA	
91000026	B-501SA	
91000027	B-801SA	
91000053	B-1300SS	
91000054	B-1500SS	



B-1300SS

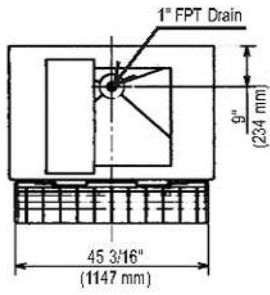

TOP VIEW
B-1150/1300SS

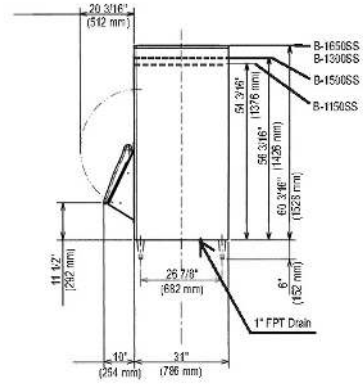
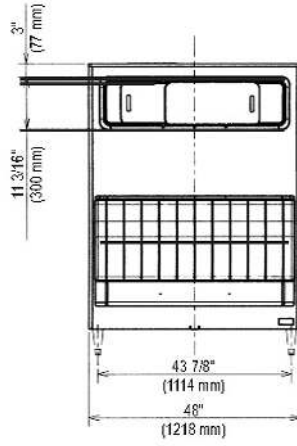

B-1500SS



B-1500SS

<i>Product Specifications</i>	
<i>BIN CAPACITY</i>	680kg
<i>DIMENSIONS W x D x H (INCL LEGS)</i>	1523mm x 1040mm x 1578mm
<i>WEIGHT (NET)</i>	159kg
<i>TOP KITS: IM240D</i>	Universal
<i>TOP KITS: KM900</i>	Universal
<i>TOP KITS: IM240A, KM650, FM300, FM600</i>	Universal
<i>TOP KITS: KMD201, KMD270</i>	Universal
<i>TOP KITS: 2 x IM240A, 2 x KM650, 2 x FM300, 2 x FM600</i>	Universal
<i>TOP KITS: 2 x KMD201, 2 x KMD270</i>	Universal
<i>TOP KITS: KM1301, KM2100</i>	Universal
<i>TOP KITS: FM1000, FM1200</i>	Universal
<i>TOP KITS: FM1800</i>	Universal

<i>Product Range</i>		
<i>PART NO.</i>	<i>DESCRIPTION</i>	<i>LIST PRICE</i>
91000025	B-301SA	
91000026	B-501SA	
91000027	B-801SA	
91000053	B-1300SS	
91000054	B-1500SS	

B-1500SS

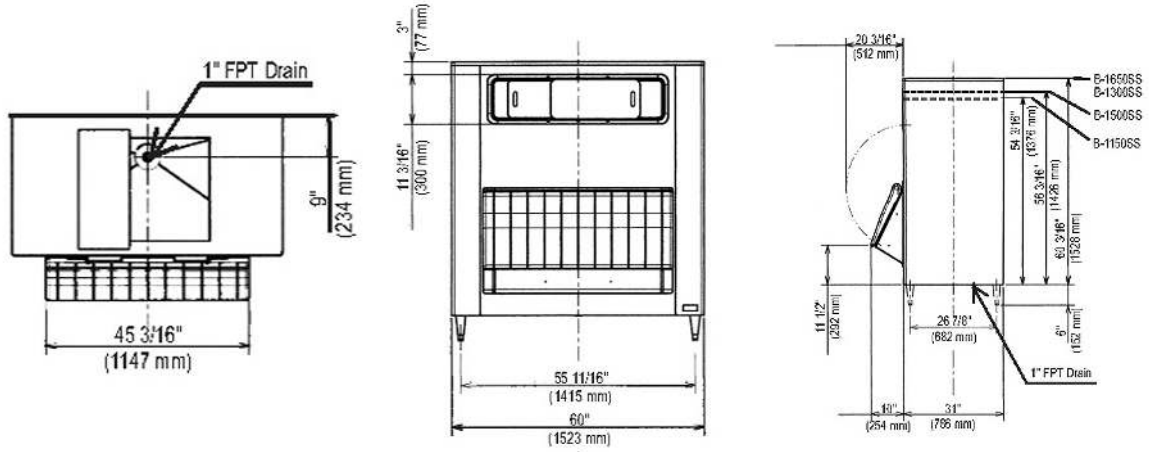

WATER FILTERS



<i>Product Specifications</i>	
<i>87000104 - WATER FILTER HLF10 COMPLETE WITH BRACKET SMALL</i>	Suitable for: IM's 30, 45, 65, 100 NE & CNE Units KM's 30, 50, 75, 100, 125 Units FM & (N) 120, 150 Units Dispensers DCM60, DCM110, DIM30 Units
<i>87000105 - WATER FILTER HLF20 COMPLETE WITH BRACKET LARGE</i>	Suitable for: IM's 130 & all 240 Units KM's 201, 650 and KMD-270 Units FM & (N) 300, 600 Units Dispensers DCM230 Units
<i>87000123 - FILTER PARALLEL HLF32 COMPLETE WITH BRACKET EXTRA LARGE</i>	Suitable for: KM's 900, 1300 - 2100 Units FM 1200 & 1800 Units
<i>87000106 - REPLACEMENT HLFC10 CARTRIDGE ONLY SMALL</i>	Suitable for: IM's 30, 45, 65, 100, NE & CNE Units KM's 30, 50, 75, 100, 125 Units FM & (N) 120, 150 Units Dispensers DCM60, DCM110, DIM30 Units
<i>81000107 - REPLACEMENT HLFC20 CARTRIDGE ONLY LARGE</i>	Suitable for: IM's 130 & all 240 Units KM's 201, 650 and KMD-270 Units FM & (N) 300, 600 Units Dispensers DCM230 Units
<i>81000116 - 2M WATER SUPPLY HOSE</i>	Connecting hose suitable for all machines
<i>06000036 - INSTALLATION KIT (KM HEADS ONLY)</i>	Installation kit used only for KM Units KM's 201, 650, 900, 1300 - 2100 Units KMD-270 Units



WATER FILTERS



78000098 - DRAIN PUMP	4.5m head Low Profile
78000099 - DRAIN PUMP	Suits all self contained ice makers

Product Range			
REF NO.	PART NO.	DESCRIPTION	LIST PRICE
1	87000104	WATER FILTER HLF10 COMPLETE WITH BRACKET SMALL	
2	87000105	WATER FILTER HLF20 COMPLETE WITH BRACKET LARGE	
3	87000123	FILTER PARALLEL HLF32 COMPLETE WITH BRACKET EXTRA LARGE	
4	87000106	REPLACEMENT HLFC10 CARTRIDGE ONLY SMALL	
5	87000107	REPLACEMENT HLFC20 CARTRIDGE ONLY LARGE	
6	81000116	2M WATER SUPPLY HOSE	
7	06000036	INSTALLATION KIT (KM HEADS ONLY)	
8	78000098	DRAIN PUMP	
9	78000099	DRAIN PUMP	





PROFESSIONAL SERIES REFRIGERATION & FREEZERS



Hoshizaki Foodservice Equipment

www.hoshizaki.com.au

PROFESSIONAL SERIES REFRIGERATION & FREEZERS

Hoshizaki refrigeration products are designed for kitchen professionals who demand a reliable cost effective and easy to maintain product.

Constructed from first class materials, the exterior and interior of the refrigerators and freezers are made of stainless steel. The under counters have an inside door cover of grey ABS. The temperature range for the upright refrigerators is 0°C to +16°C and -6°C to +12°C for the under counter refrigerator. The temperature range for the upright and under counter freezers are -27°C to -7°C. Both the upright and under counter series are rated to 43°C operating ambient, and HACCP approved.

Hoshizaki refrigeration is incredibly energy efficient through the use of DC fan motors. Front located removable, cleanable air filters means ease of maintenance and reduced service issues.

The upright reach in range comprises single and double door refrigerators and freezers with 631 and 1372 litre capacities respectively, while the under counter range offers two and three door models with capacities from 265 to 412 litres. Drawers are an option.

Hoshizaki refrigeration features integrated electronic controls, heavy duty castors and automatic defrost. The upright range also features self-closing, lockable doors for convenience and security.



PRODUCT HIGHLIGHTS



PRODUCT HIGHLIGHTS

STANDARD PRODUCT RANGE

This range is made up of gastronorm 2/1 cabinets and 1/1 counters, available as a refrigerator or freezer with cabinets available in single, double and split doors and counters in double and triple door.

- Carefully designed to ensure the optimal circulation of air at all times.
- Refrigerated air is circulated around the cabinet to maintain the storage of foodstuffs at the correct temperature using an energy efficient DC Fan.
- Exterior and interior are made of stainless steel. Counters have an inside door cover of grey ABS.
- Temperature ranges:
Cabinet: 0 to 16 & -25 to -7
Counter: -6 to 12 & -25 to -7
- These counters and cabinets offer great versatility as they can be used for different types of storage as requirements change or seasonal changes dictate menu variations.



PRODUCT HIGHLIGHTS

CUSTOMER BENEFITS

COUNTER



- The Stainless steel composition of the machine allows the worktop to double-up as a food preparation area, reducing the footprint of the machine in frequently space-restricted commercial environments.
- The compressor assembly can be easily accessed or removed from the machine, allowing easy maintenance and reducing costs*.
- An energy efficient DC fan (80% more energy efficient than AC fan) considerably reduces the amount of energy consumed by the machine, reducing its impact on both the environment and your finances.

UPRIGHT



- An energy efficient DC fan (80% more energy efficient than AC fan) considerably reduces the amount of energy consumed.
- Routine cleaning and maintenance schedules are quick and easy to carry out, facilitated by the ergonomic design of the unit.
- Machines in this range include automatically closing doors (when an angle of less than 90 degrees). This reduces the risk of doors accidentally being left open, increasing the amount of energy consumed, and avoiding product spoil.
- The front frame of the freezer cabinet is heated, which when combined with the units efficient insulation, mean that condensation cannot build up on the exterior panels of the cabinet.
- The evaporator defrost cycle of the freezer is scheduled to run every six hours, maintaining energy efficiency by reducing the build up of ice on the evaporator.

These units are supplied with castors as standard allowing them to be easily moved when looking to relocate equipment, or for cleaning purposes. Legs are optional.

PROFESSIONAL COUNTER REFRIGERATION & FREEZERS

Hoshizaki refrigeration and freezer products are designed for professional kitchens who demand a reliable easy to maintain product with a low cost of ownership.



Easy Cleaning

Removable door gaskets for easy cleaning without the need for tools



Adjustable Shelves

The counter offers one height adjustable shelf per section as standard



Hygienic Design

Dished stainless interior and base with rounded edges for easy cleaning



User friendly controller

Control panel with digital thermometer / thermostat for accurate control and easy reading. A transparent plastic cover protects against accidental adjustment of temperature and fluid spillage.



Easy Service

A compact slide out refrigeration unit for easy maintenance and service access.



Easy Maintenance

Easy access to front loaded air filter for cleaning.

RTE-120SDA-GN COUNTER REFRIGERATOR



<i>Product Specifications</i>	
<i>WEIGHT</i>	Net: 83kg Gross: 93kg
<i>AC SUPPLY VOLTAGE</i>	220 - 240V / 50Hz / 1
<i>AMPERAGE</i>	1.4A
<i>STARTING AMPERAGE</i>	6.8A
<i>DEFROST SYSTEM</i>	Heater
<i>TEMPERATURE CONTROL</i>	Microprocessor controlled - Adjustable from -6°C to 12°C
<i>EFFECTIVE CAPACITY</i>	265L
<i>AMBIENT TEMPERATURE</i>	5 - 43°C
<i>REFRIGERANT</i>	R134a
<i>EXTERIOR</i>	Stainless Steel, Galvanised Steel (Rear/Bottom)
<i>INTERIOR</i>	Stainless Steel ABS Plastic
<i>DOOR / SHELF</i>	2 Door / 2 Shelf
<i>Castors</i>	Comes standard with 76mm castors and 115mm floor clearance

<i>Product Range</i>		
<i>PART NO.</i>	<i>DESCRIPTION</i>	<i>LIST PRICE</i>
97000007	RTE-120SDA-GN	

RTE-120SDA-GN COUNTER REFRIGERATOR

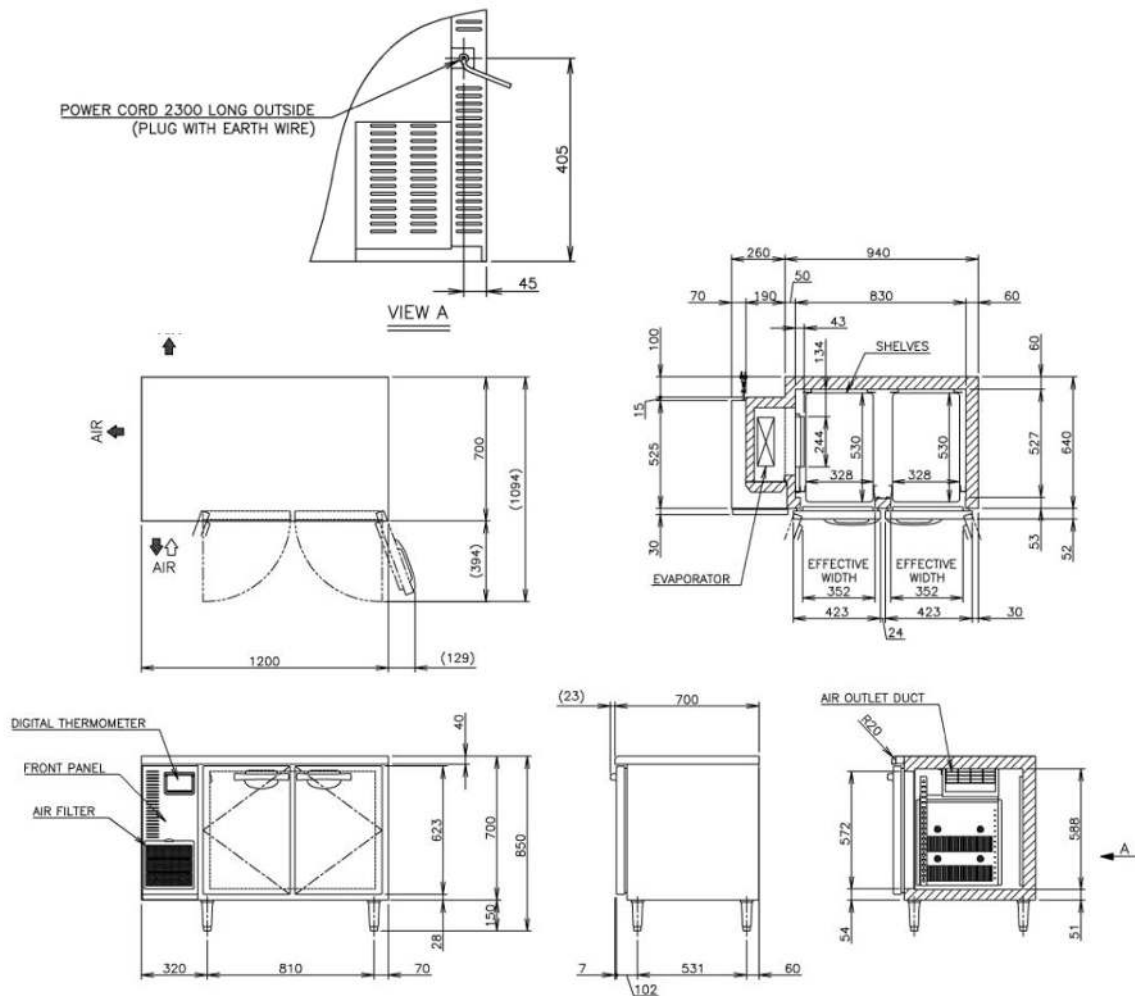

FTC-125SDA-GN COUNTER FREEZER



<i>Product Specifications</i>	
<i>SPECIFICATIONS (mm)</i>	1250W x 750D x 815H
<i>WEIGHT</i>	Net: 87kg Gross: 97kg
<i>AC SUPPLY VOLTAGE</i>	220 - 240V / 50Hz / 1
<i>AMPERAGE</i>	2.8A
<i>STARTING AMPERAGE</i>	13.0A
<i>DEFROST SYSTEM</i>	Glass Tube Heater
<i>TEMPERATURE CONTROL</i>	Microprocessor controlled - adjustable from -25°C to -7°C
<i>EFFECTIVE CAPACITY</i>	265L
<i>AMBIENT TEMPERATURE</i>	5 - 43°C
<i>REFRIGERANT</i>	R404A
<i>EXTERIOR</i>	Stainless Steel, Galvanised Steel (Rear / Bottom)
<i>INTERIOR</i>	Stainless Steel ABS Plastic
<i>DOOR / SHELF</i>	2 Door / 2 Shelf
<i>CASTORS</i>	Comes standard with 76mm castors and 115mm floor clearance

<i>Product Range</i>		
<i>PART NO.</i>	<i>DESCRIPTION</i>	<i>LIST PRICE</i>
97000005	FTE-120SDA-GN	

FTC-125SDA-GN COUNTER FREEZER

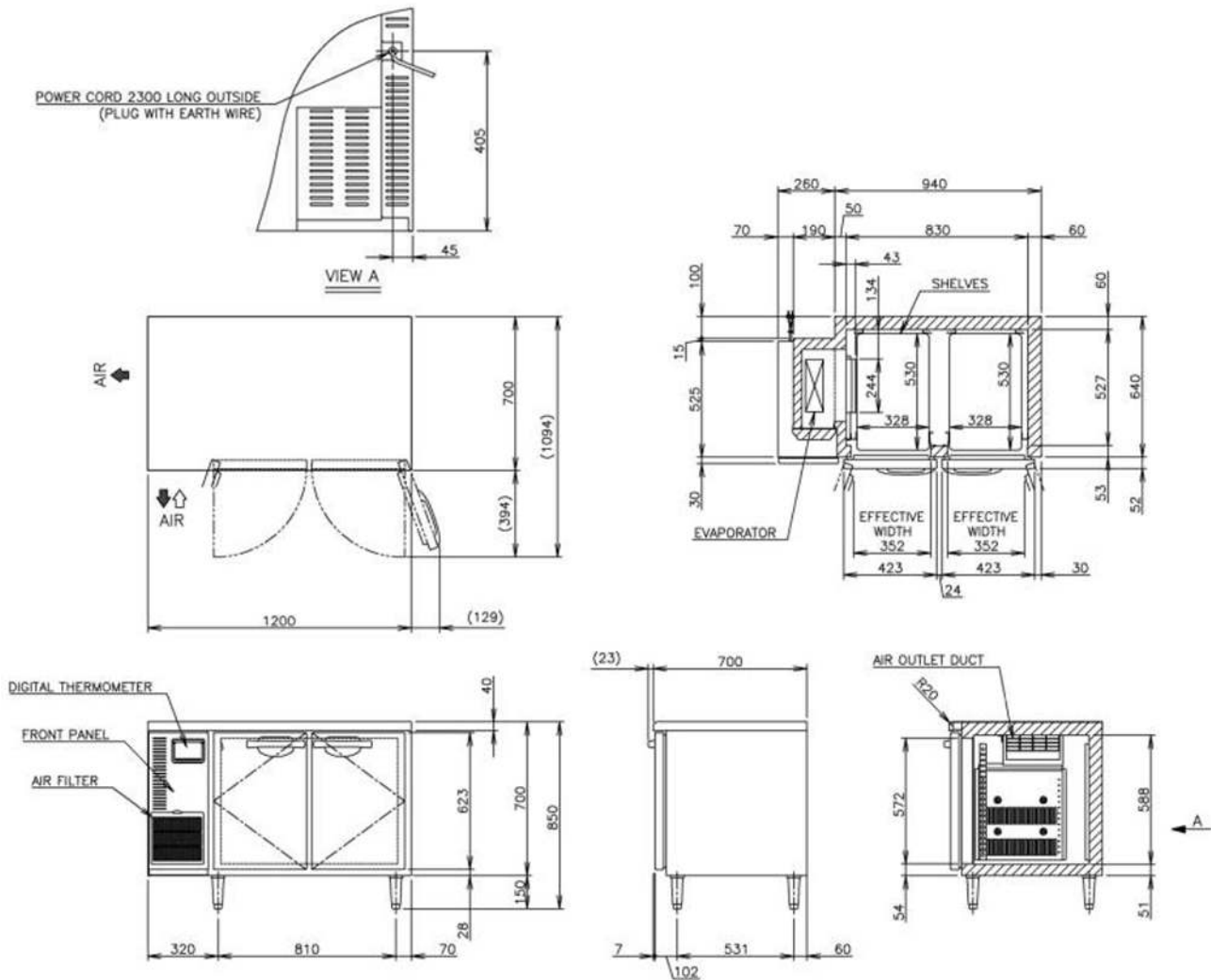

RTE-170SDA-GN COUNTER REFRIGERATOR



<i>Product Specifications</i>	
<i>WEIGHT</i>	Net: 103kg Gross: 115kg
<i>AC SUPPLY VOLTAGE</i>	220 - 240V / 50Hz / 1
<i>AMPERAGE</i>	1.4A
<i>STARTING AMPERAGE</i>	6.8A
<i>DEFROST SYSTEM</i>	Heater
<i>TEMPERATURE CONTROL</i>	Microprocessor controlled - adjustable from -6°C to 12°C
<i>AMBIENT TEMPERATURE</i>	5 - 43°C
<i>EFFECTIVE CAPACITY</i>	412L
<i>REFRIGERANT</i>	R134a
<i>EXTERIOR</i>	Stainless Steel, Galvanised Steel (Rear/Bottom)
<i>INTERIOR</i>	Stainless Steel, ABS Plastic
<i>DOOR / SHELF</i>	3 Door / 3 Shelf
<i>CASTORS</i>	Comes standard with 76mm castors and 115mm floor clearance

<i>Product Range</i>		
<i>PART NO.</i>	<i>DESCRIPTION</i>	<i>LIST PRICE</i>
97000008	RTE-170SDA-GN	

FTE-170SDA-GN COUNTER FREEZER



<i>Product Specifications</i>	
<i>WEIGHT</i>	Net: 109kg Gross: 121kg
<i>AC SUPPLY VOLTAGE</i>	220 - 240V / 50Hz / 1
<i>AMPERAGE</i>	3.4A
<i>STARTING AMPERAGE</i>	14.8A
<i>DEFROST SYSTEM</i>	Glass Tube Heater
<i>TEMPERATURE CONTROL</i>	Microprocessor controlled - adjustable from -25°C to -7°C
<i>AMBIENT TEMPERATURE</i>	5 - 43°C
<i>EFFECTIVE CAPACITY</i>	412L
<i>REFRIGERANT</i>	R404A
<i>EXTERIOR</i>	Stainless Steel, Galvanised Steel (Rear / Bottom)
<i>INTERIOR</i>	Stainless Steel, ABS Plastic
<i>DOOR / SHELF</i>	3 Door / 3 Shelf
<i>CASTORS</i>	Comes standard with 76mm castors and 115mm floor clearance

<i>Product Range</i>		
<i>PART NO.</i>	<i>DESCRIPTION</i>	<i>LIST PRICE</i>
97000006	FTE-170SDA-GN	



FTE-170SDA-GN COUNTER FREEZER

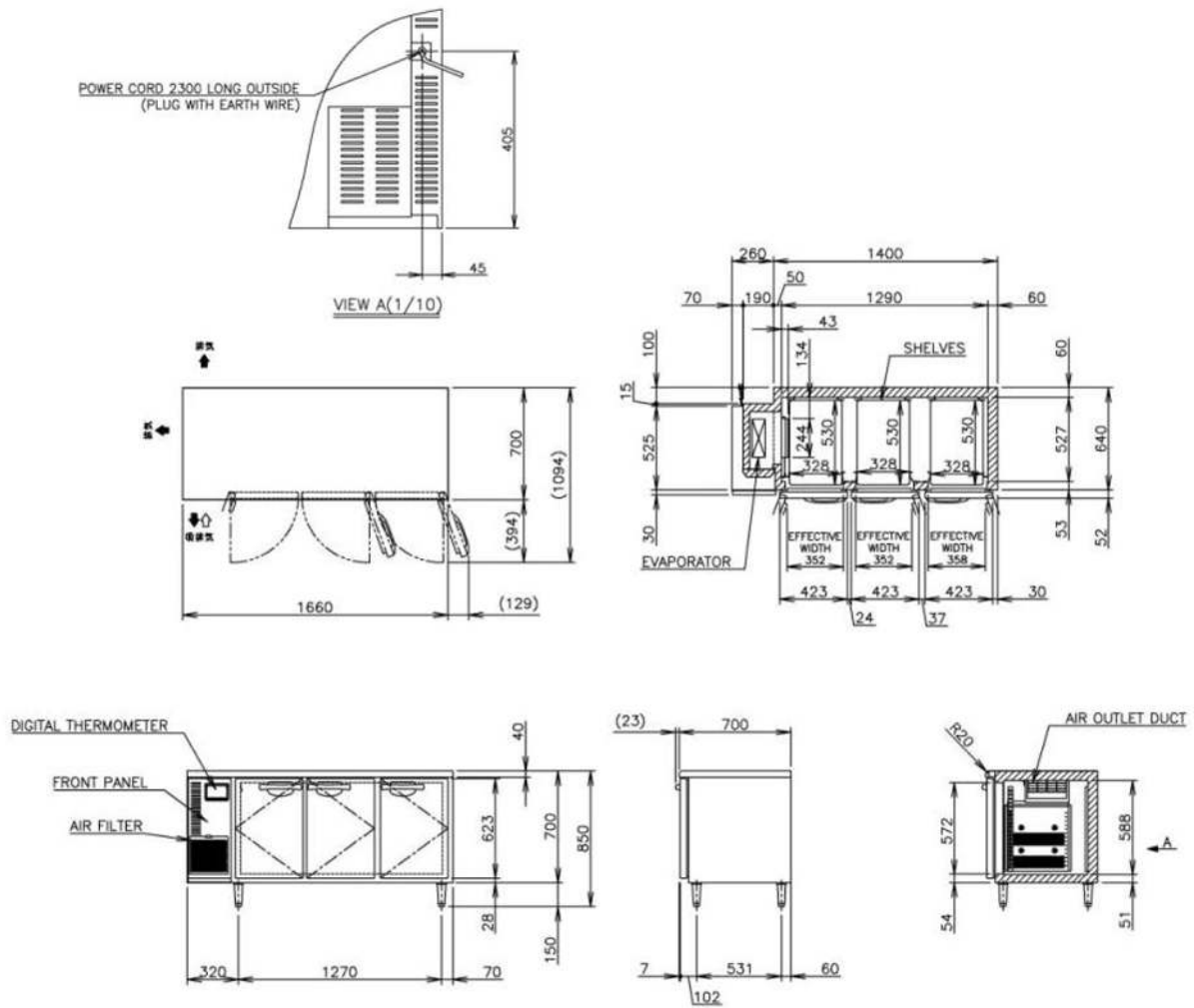

PROFESSIONAL UPRIGHT REACH IN REFRIGERATION & FREEZERS

Hoshizaki refrigeration and freezer products are designed for professional kitchens who demand a reliable easy to maintain product with a low cost of ownership.



Easy Cleaning

Removable door gaskets for easy cleaning without the need for tools.



Adjustable Shelves

The counter offers one height adjustable shelf per section as standard.



Hygienic Design

Dished stainless interior and base with rounded edges for easy cleaning.



User friendly controller

Control panel with digital thermometer / thermostat for accurate control and easy reading. A transparent plastic cover protects against accidental adjustment of temperature and fluid spillage.



Easy Service*

A compact slide out refrigeration unit for easy maintenance and service access.

HRE-70B UPRIGHT REACH IN REFRIGERATOR



<i>Product Specifications</i>	
<i>WEIGHT</i>	Net: 116kg / Packed: 131kg
<i>AC SUPPLY VOLTAGE</i>	220 - 240v / 50Hz / 1
<i>ELECTRIC CIRCUIT PROTECTION</i>	Earth Wire, Circuit Breaker
<i>INTERIOR / EXTERIOR</i>	Stainless Steel / Stainless Steel, Galvanized Steel (Rear, Bottom)
<i>AMPERAGE</i>	2.06A
<i>REFRIGERATION SYSTEM</i>	Forced Air Circulation Interior Fan - DC12V 4W x 1
<i>DEFROST SYSTEM</i>	Off-Cycle
<i>TEMPERATURE CONTROL</i>	Microprocessor (Digital temp. indication) - Adjustable from 0°C to 16°C
<i>DEFROST CONTROL</i>	Microprocessor
<i>DRAIN EVAPORATOR PAN</i>	Stainless steel, 170W
<i>CASTOR</i>	Urethane (76mm DIA, 115mm High)
<i>EFFECTIVE CAPACITY</i>	Approx. 631L
<i>INSULATION</i>	Polyurethane foam
<i>REFRIGERANT</i>	R134a
<i>HEAT REJECTION</i>	535W at 43°C ambient
<i>AMBIENT TEMPERATURE</i>	5 — 43°C

<i>Product Range</i>		
<i>PART NO.</i>	<i>DESCRIPTION</i>	<i>LIST PRICE</i>
97000001	HRE-70B	

HRE-70B UPRIGHT REACH IN REFRIGERATOR

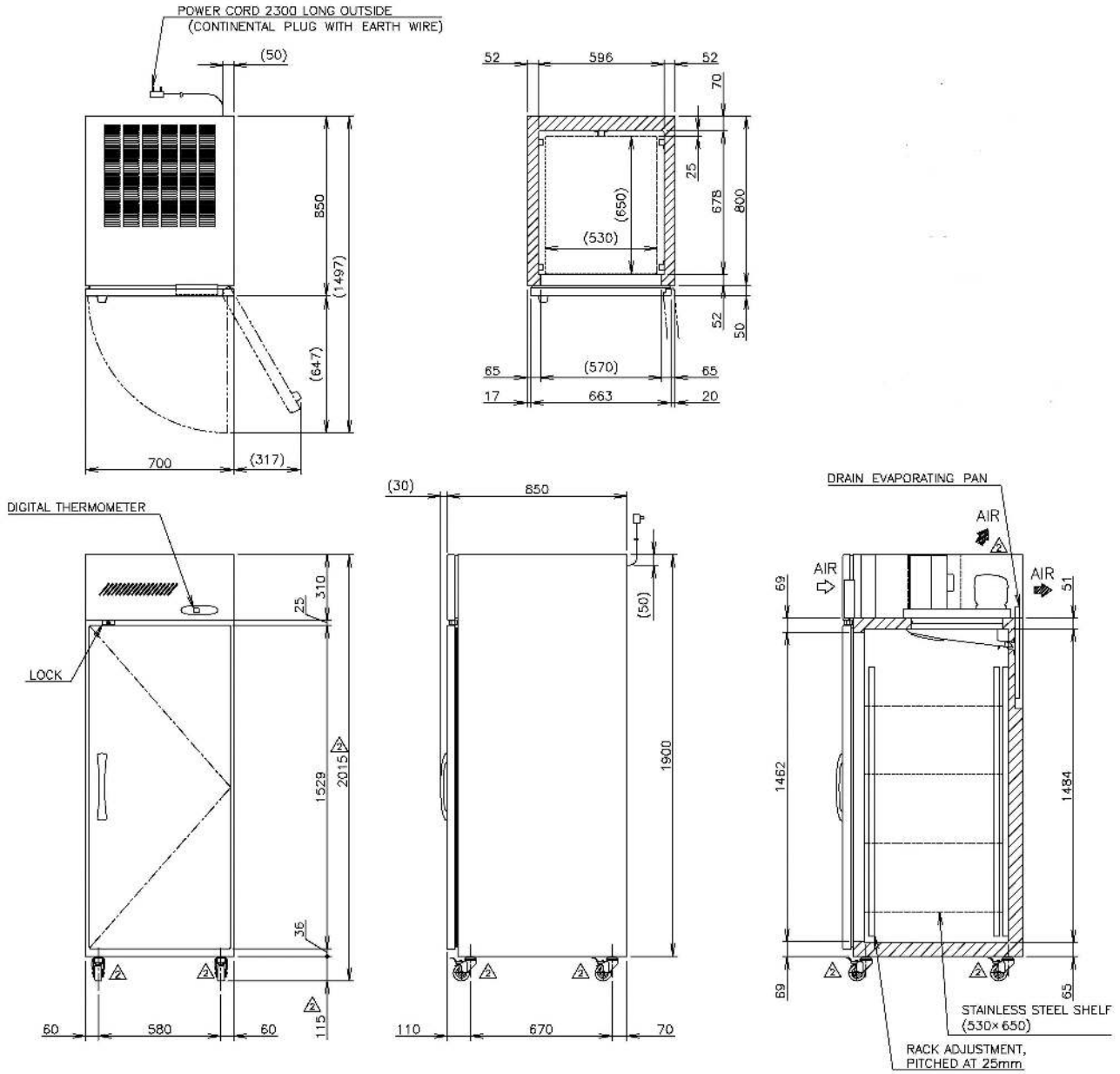

HFE-70B UPRIGHT FREEZER



<i>Product Specifications</i>	
<i>WEIGHT</i>	Net: 116kg / Packed: 131kg
<i>AC SUPPLY VOLTAGE</i>	220 - 240V / 50Hz / 1
<i>ELECTRIC CIRCUIT PROTECTION</i>	Earth Wire, Circuit Breaker
<i>INTERIOR / EXTERIOR</i>	Stainless Steel / Stainless Steel, Galvanized Steel (Rear, Bottom)
<i>AMPERAGE</i>	3.51A
<i>REFRIGERATION SYSTEM</i>	Forced Air Circulation Interior Fan - DC12V 4W x 2
<i>DEFROST SYSTEM</i>	Heater
<i>TEMPERATURE CONTROL</i>	Microprocessor (Digital temp. indication) - Adjustable from -25°C to -7°C
<i>DEFROST CONTROL</i>	Microprocessor
<i>DRAIN EVAPORATOR PAN</i>	Stainless Steel, 170W
<i>CASTOR</i>	Urethane (76mm DIA, 115mm High)
<i>EFFECTIVE CAPACITY</i>	Approx. 631L
<i>INSULATION</i>	Polyurethane Foam
<i>REFRIGERANT</i>	R404A
<i>HEAT REJECTION</i>	735W at 43°C ambient
<i>AMBIENT TEMPERATURE</i>	5 - 43°C

<i>Product Range</i>		
<i>PART NO.</i>	<i>DESCRIPTION</i>	<i>LIST PRICE</i>
97000003	HFE-70B	

HFE-70B UPRIGHT FREEZER

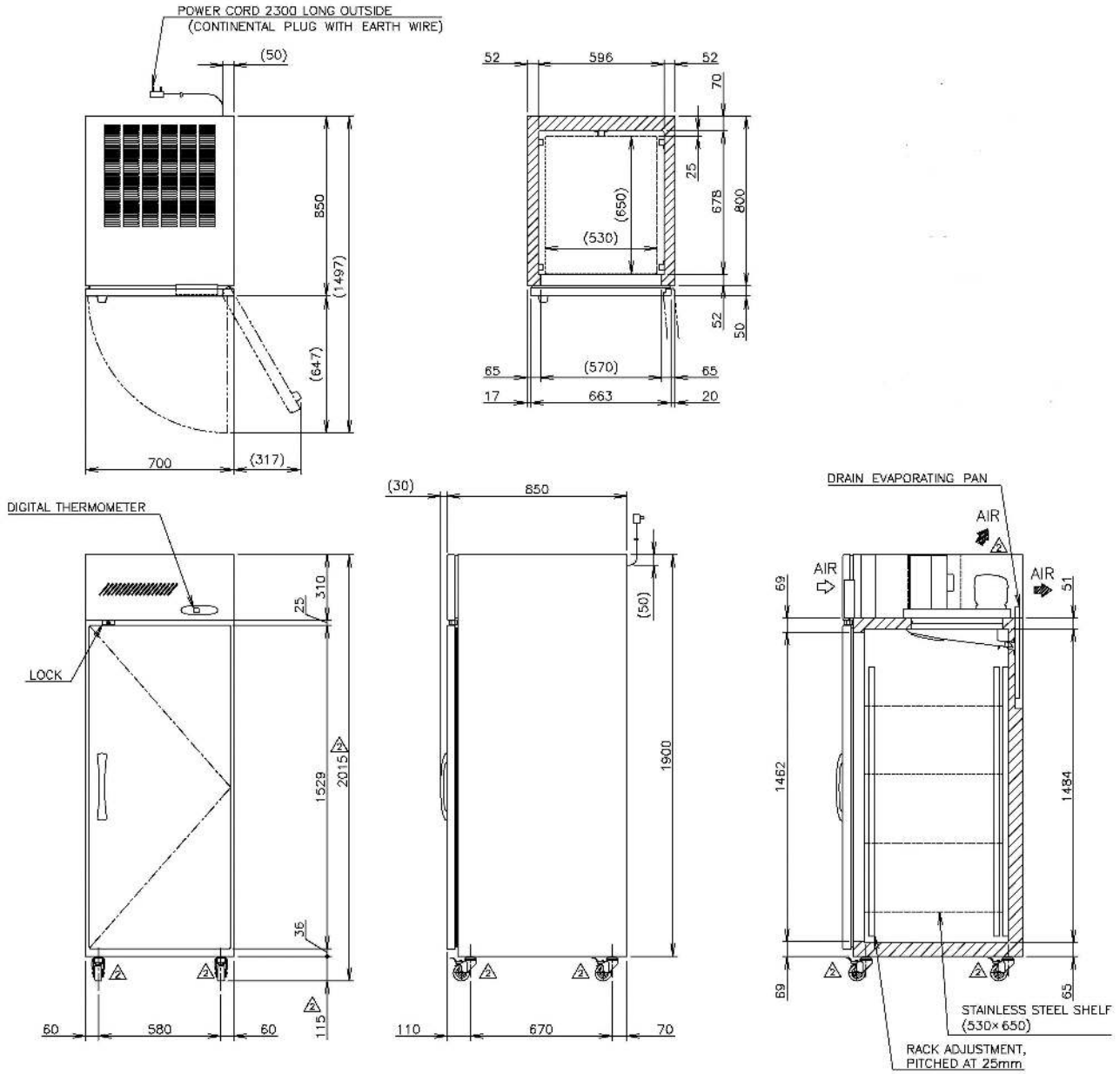

HRE-140B UPRIGHT REACH IN REFRIGERATOR



<i>Product Specifications</i>	
<i>WEIGHT</i>	Net: 164kg Packed: 189kg
<i>AC SUPPLY VOLTAGE</i>	220 - 240v / 50Hz / 1
<i>ELECTRIC CIRCUIT PROTECTION</i>	Earth Wire, Circuit Breaker
<i>INTERIOR / EXTERIOR</i>	Stainless Steel / Stainless Steel, Galvanized Steel (Rear, Bottom)
<i>AMPERAGE</i>	2.89A
<i>REFRIGERATION SYSTEM</i>	Forced Air Circulation Interior Fan - DC12V 4W x 1
<i>DEFROST SYSTEM</i>	Off-Cycle
<i>TEMPERATURE CONTROL</i>	Microprocessor (Digital temp. indication) - Adjustable from 0°C to 16°C
<i>DEFROST CONTROL</i>	Microprocessor
<i>DRAIN EVAPORATOR PAN</i>	Stainless steel, 170W
<i>CASTOR</i>	Urethane (76mm DIA, 115mm High)
<i>EFFECTIVE CAPACITY</i>	Approx. 1379L
<i>INSULATION</i>	Polyurethane foam
<i>REFRIGERANT</i>	R134a
<i>HEAT REJECTION</i>	940W at 43°C ambient
<i>AMBIENT TEMPERATURE</i>	5 — 43°C

<i>Product Range</i>		
<i>PART NO.</i>	<i>DESCRIPTION</i>	<i>LIST PRICE</i>
97000002	HRE-140B	

HRE-140B UPRIGHT REACH IN REFRIGERATOR

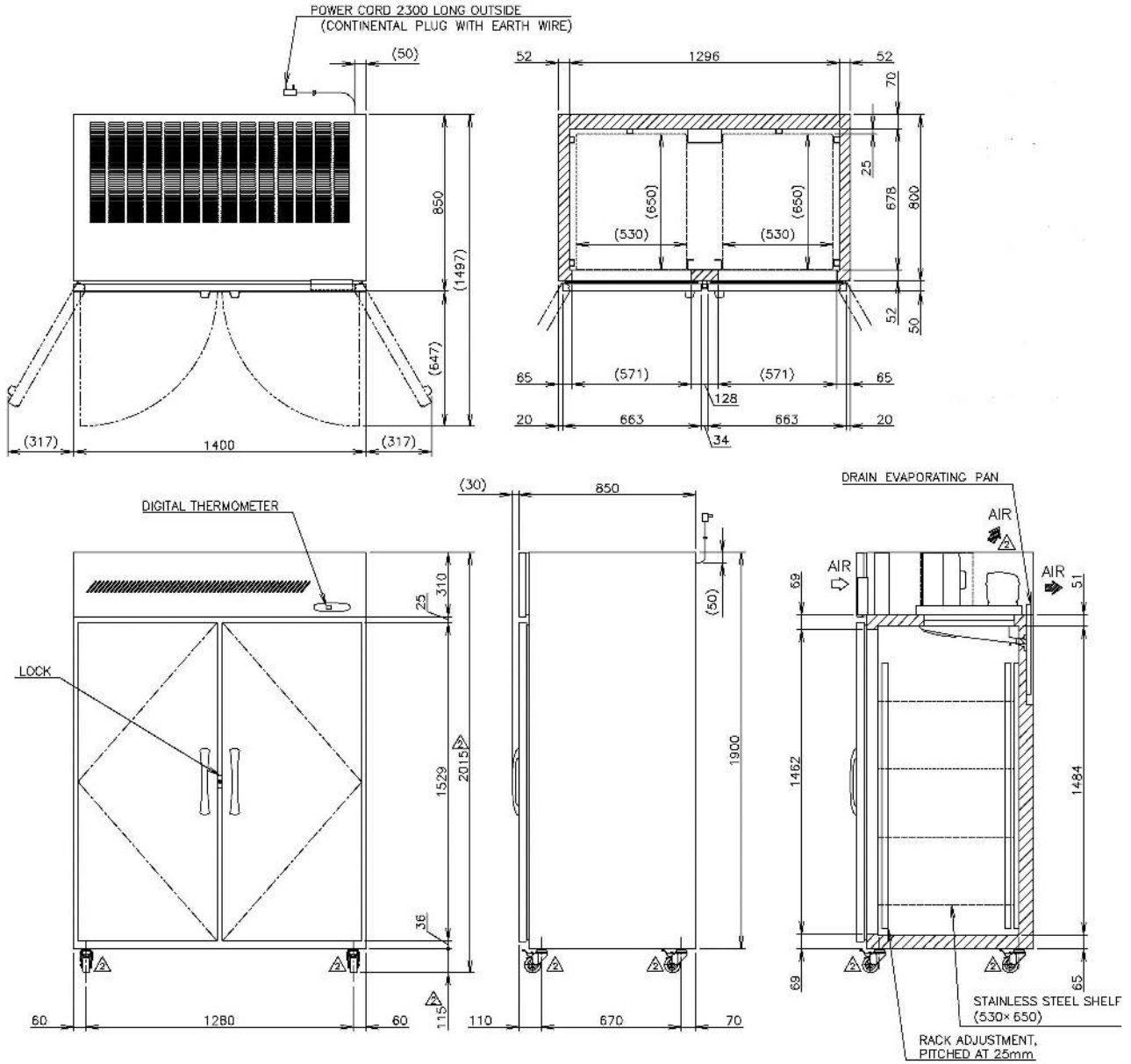

HFE-140B UPRIGHT REACH IN FREEZER



<i>Product Specifications</i>	
<i>WEIGHT</i>	Net: 174kg Packed: 199kg
<i>AC SUPPLY VOLTAGE</i>	220 - 240V / 50Hz / 1
<i>ELECTRIC CIRCUIT PROTECTION</i>	Earth Wire, Circuit Breaker
<i>INTERIOR / EXTERIOR</i>	Stainless Steel / Stainless Steel, Galvanized Steel (Rear, Bottom)
<i>AMPERAGE</i>	3.79A
<i>REFRIGERATION SYSTEM</i>	Forced Air Circulation Interior Fan - DC12V 4W x 3
<i>DEFROST SYSTEM</i>	Heater
<i>TEMPERATURE CONTROL</i>	Microprocessor (Digital temp. indication) - Adjustable from -25°C to -7°C
<i>DEFROST CONTROL</i>	Microprocessor
<i>DRAIN EVAPORATOR PAN</i>	Stainless Steel, 170W
<i>CASTOR</i>	Urethane (76mm DIA, 115mm High)
<i>EFFECTIVE CAPACITY</i>	Approx 1372L
<i>INSULATION</i>	Polyurethane Foam
<i>REFRIGERANT</i>	R404A
<i>HEAT REJECTION</i>	1330W
<i>AMBIENT TEMPERATURE</i>	5 - 43°C

<i>Product Range</i>		
<i>PART NO.</i>	<i>DESCRIPTION</i>	<i>LIST PRICE</i>
97000004	HFE-140B	

HFE-140B UPRIGHT REACH IN FREEZER

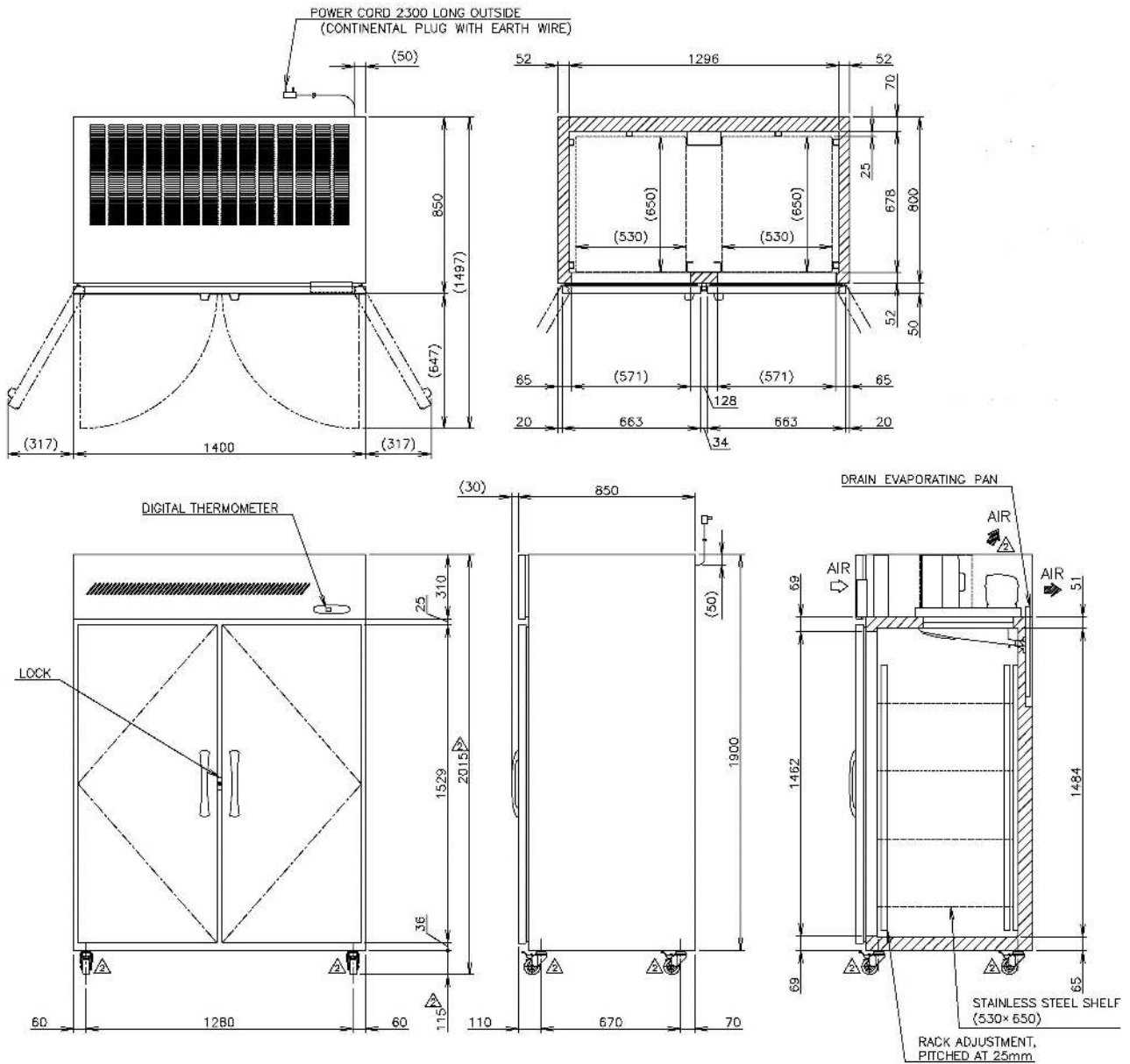



COMMERCIAL SERIES REFRIGERATION & FREEZERS



Hoshizaki Foodservice Equipment

www.hoshizaki.com.au

COMMERCIAL SERIES REFRIGERATION & FREEZERS

The Hoshizaki Commercial series of refrigerators and freezers are unsurpassed when it comes to reliability and value for money.

A high operating ambient temperature (43°C for upright cabinets & 38°C for counter cabinets) ensures that the Commercial series meets your demands in all conditions.

The Commercial series offer many features including:

- *Split ½ doors for the upright Refrigeration and Freezers.*
- *Food service size internal shelving systems that allow full interior usage.*
- *Fully programmable digital controller.*
- *HACCP approved.*

Available in a variety of sizes and styles to suit all needs, these cabinets are designed for everyday commercial kitchen usage.

So when it comes to refrigeration and freezers for your commercial kitchen, think **Hoshizaki Commercial**.



COMMERCIAL COUNTER SERIES REFRIGERATION & FREEZERS

Hoshizaki refrigeration and freezer products are designed for professional kitchens who demand a reliable easy to maintain product with a low cost of ownership.



Easy Cleaning

Removable door gaskets for easy cleaning without the need for tools.



Adjustable Shelves

The counter offers 2 per door on counter cabinets (includes bottom shelf).



Hygienic Design

Dished stainless interior and base with rounded edges for easy cleaning.



User friendly controller

Control panel with digital thermometer / thermostat for accurate control and easy reading. A transparent plastic cover protects against accidental adjustment of temperature and fluid spillage.



Easy Maintenance

Easy access to front loaded air filter for cleaning.

RTC-120MNA COUNTER REFRIGERATOR



<i>Product Specifications</i>	
<i>Weight</i>	Net: 67kg Gross: 72kg
<i>AC supply voltage</i>	200 - 240V / 50Hz
<i>Interior / Exterior</i>	Stainless steel (ABS plastic interior doors)
<i>Amperage</i>	10A
<i>Refrigeration System</i>	Forced air circulation
<i>Defrost System</i>	Off cycle
<i>Temperature control</i>	Microprocessor adjustable from 0°C to 12°C
<i>Drain Evaporator Pan</i>	Fin & Tube type
<i>Effective capacity</i>	231L
<i>Refrigerant</i>	R134a
<i>Door / Shelf</i>	2 Door / 4 Shelves
<i>Heat Rejection</i>	350W
<i>Ambient Temperature</i>	5°C - 38°C
<i>Castors</i>	Comes standard with 76mm castors = 115mm floor clearance

<i>Product Range</i>		
<i>PART NO.</i>	<i>DESCRIPTION</i>	<i>LIST PRICE</i>
97000050	RTC-120-MNA	

RTC-120MNA COUNTER REFRIGERATOR

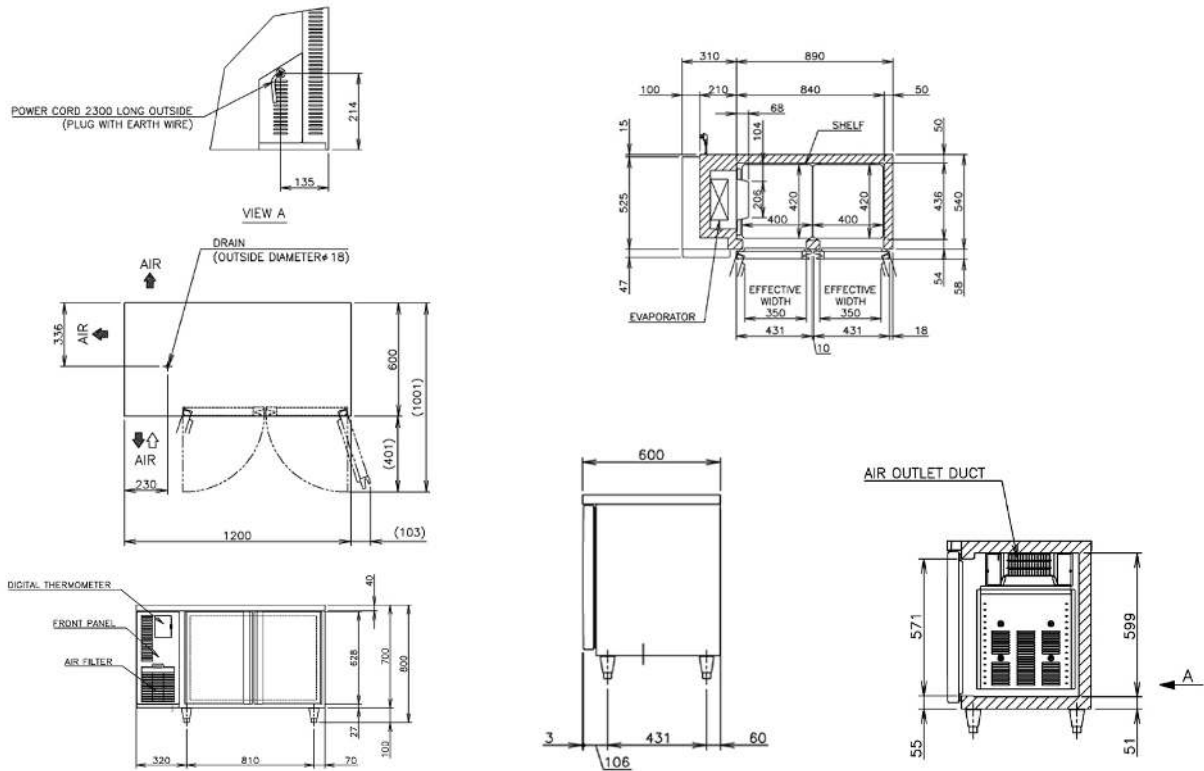

FTC-120MNA COUNTER FREEZER



<i>Product Specifications</i>	
<i>Weight</i>	Net: 72kg Gross: 77kg
<i>AC supply voltage</i>	220 - 240V / 50Hz
<i>Interior / Exterior</i>	Stainless steel (ABS plastic interior doors)
<i>Amperage</i>	10A
<i>Refrigeration System</i>	Forced air circulation
<i>Defrost system</i>	Glass Tube Heater
<i>Temperature control</i>	Microprocessor adjustable from -23°C to -7°C
<i>Drain evaporator pan</i>	Fin & Tube type
<i>Effective capacity</i>	231L
<i>Refrigerant</i>	R404a
<i>Door / shelf</i>	2 Door / 4 Shelves
<i>Heat rejection</i>	650W
<i>Ambient Temperature</i>	5 - 38°C
<i>Castors</i>	Comes standard with 76mm castors = 115mm floor clearance

<i>Product Range</i>		
<i>PART NO.</i>	<i>DESCRIPTION</i>	<i>LIST PRICE</i>
97000150	FTC-120-MNA	

FTC-120MNA COUNTER FREEZER

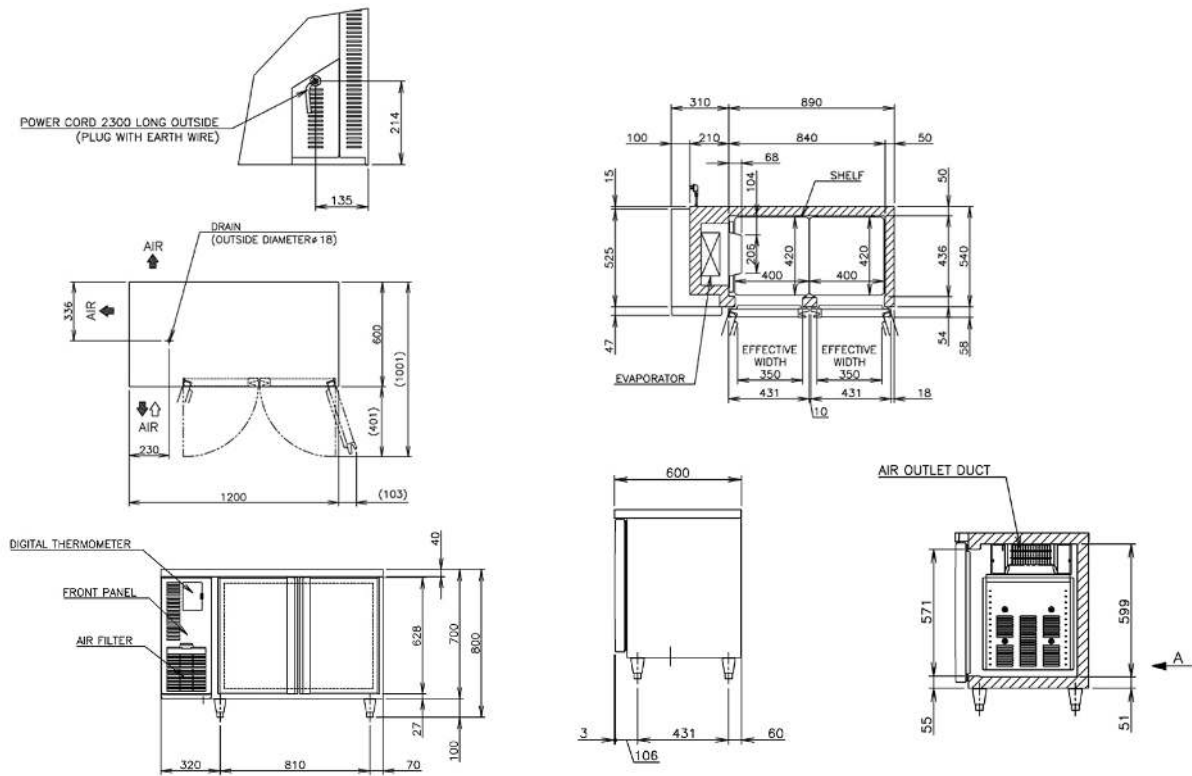

RTC-150MNA COUNTER REFRIGERATOR



<i>Product Specifications</i>	
<i>Weight</i>	Net: 80kg Gross: 85kg
<i>AC supply voltage</i>	220 - 240°C / 50Hz
<i>Interior / Exterior</i>	Stainless steel (ABS plastic interior doors)
<i>Amperage</i>	10A
<i>Refrigeration System</i>	Forced air circulation
<i>Defrost System</i>	Off cycle
<i>Temperature control</i>	Microprocessor adjustable from 0°C to 12°C
<i>Drain evaporator pan</i>	Fin & Tube type
<i>Effective capacity</i>	318L
<i>Refrigerant</i>	R134a
<i>Door / Shelf</i>	2 door / 4 shelves
<i>Ambient temperature</i>	5 - 38°C
<i>Heat Rejection</i>	360W
<i>Castors</i>	Comes standard with 76mm castors = 115mm floor clearance

<i>Product Range</i>		
<i>PART NO.</i>	<i>DESCRIPTION</i>	<i>LIST PRICE</i>
97000051	RTC-150-MNA	

RTC-150MNA COUNTER REFRIGERATOR

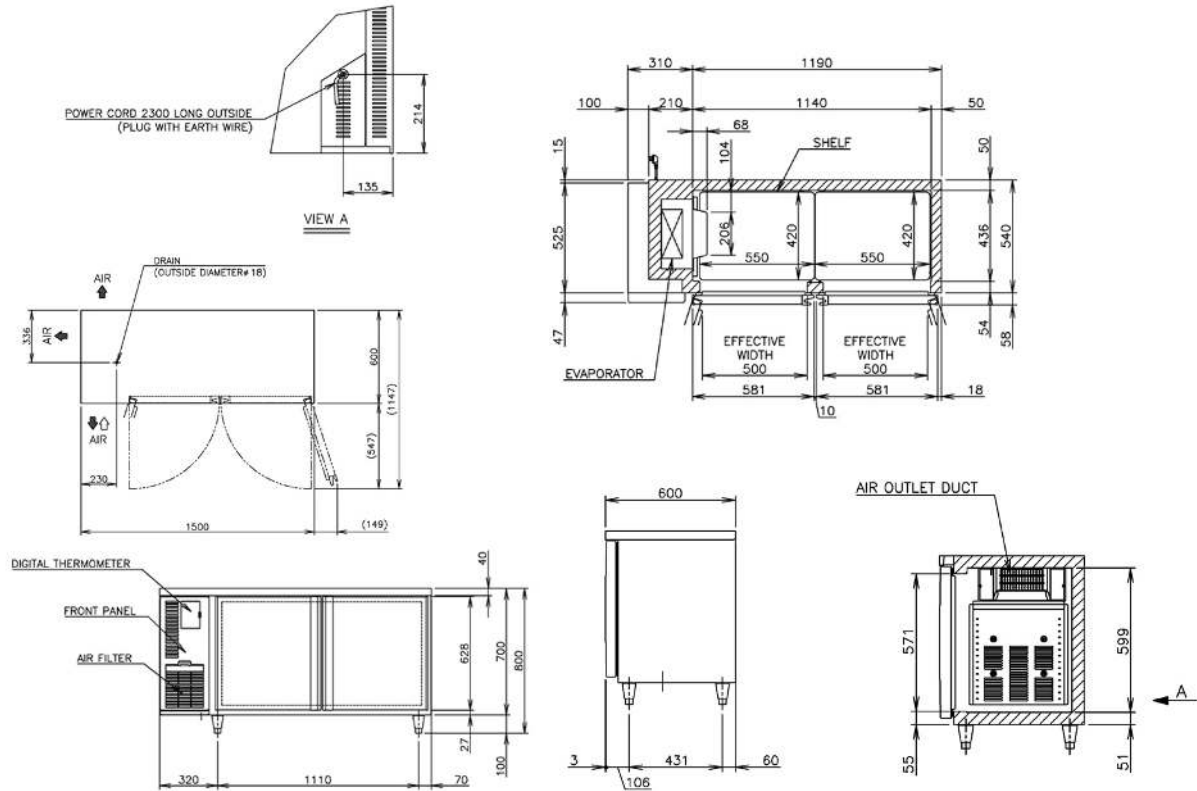

FTC-150MNA COUNTER FREEZER



<i>Product Specifications</i>	
<i>Weight</i>	Net: 86kg Gross: 91kg
<i>AC supply voltage</i>	220 - 240V / 50Hz
<i>Interior / Exterior</i>	Stainless steel (ABS plastic interior doors)
<i>Amperage</i>	10A
<i>Refrigeration system</i>	Forced air circulation
<i>Defrost System</i>	Glass tube heater
<i>Temperature control</i>	Microprocessor adjustable from -23°C to -7°C
<i>Drain evaporator pan</i>	Fin & Tube type
<i>Effective capacity</i>	318L
<i>Refrigerant</i>	R404a
<i>Door / Shelf</i>	2 Doors / 4 Shelves
<i>Ambient temperature</i>	5 - 38°C
<i>Heat rejection</i>	650W
<i>Castors</i>	Comes standard with 76mm castors = 115mm floor clearance

<i>Product Range</i>		
<i>PART NO.</i>	<i>DESCRIPTION</i>	<i>LIST PRICE</i>
97000151	FTC-150-MNA	

FTC-150MNA COUNTER FREEZER

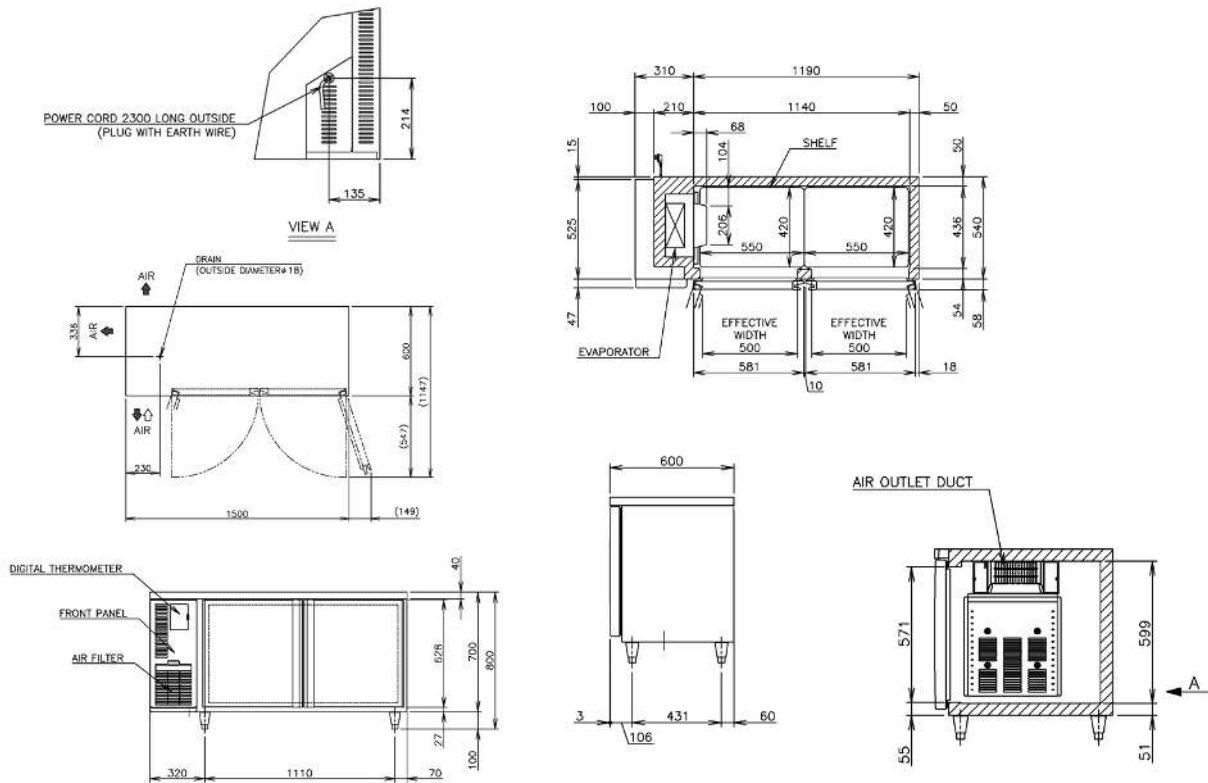

RTC-180MNA COUNTER REFRIGERATOR



<i>Product Specifications</i>	
<i>Weight</i>	Net: 93kg Gross: 99kg
<i>Ac supply voltage</i>	220 - 240V / 50Hz
<i>Interior / Exterior</i>	Stainless steel (ABS plastic interior doors)
<i>Amperage</i>	10A
<i>Refrigeration system</i>	Forced air circulation
<i>Defrost System</i>	Off cycle
<i>Temperature control</i>	Microprocessor adjustable from 0°C to 12°C
<i>Drain evaporator pan</i>	Fin & Tube type
<i>Effective capacity</i>	401L
<i>Refrigerant</i>	R134a
<i>Door / Shelf</i>	3 doors / 6 shelves
<i>Heat rejection</i>	380W
<i>Ambient temperature</i>	5 - 38°C
<i>Castors</i>	Comes standard with 76mm castors = 115mm floor clearance

<i>Product Range</i>		
<i>PART NO.</i>	<i>DESCRIPTION</i>	<i>LIST PRICE</i>
97000052	RTC-180-MNA	



RTC-180MNA COUNTER REFRIGERATOR

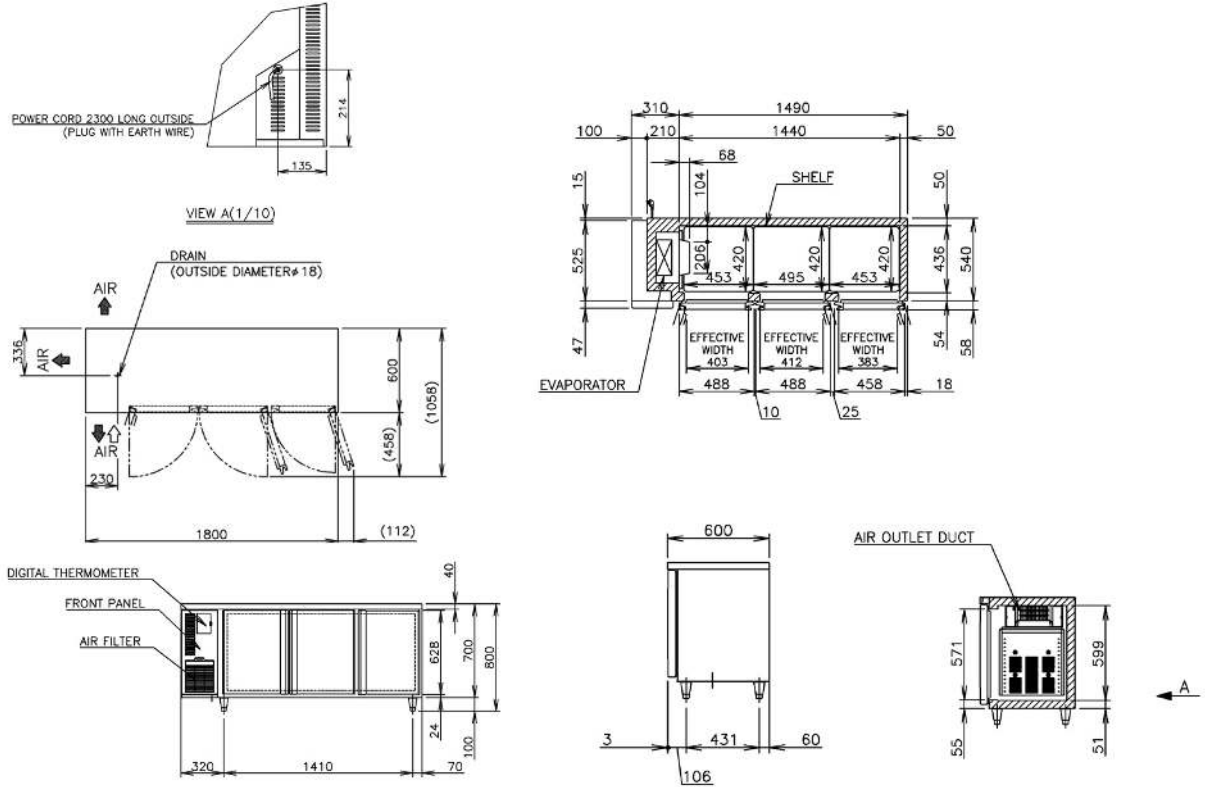

FTC-180MNA COUNTER FREEZER



Product Specifications	
Weight	Net: 99kg Gross: 105kg
AC supply voltage	220 - 240V / 50Hz
Interior / Exterior	Stainless steel (ABS plastic interior doors)
Amperage	10A
Refrigeration system	Forced air circulation
Defrost system	Glass tube heater
Temperature control	Microprocessor controlled adjustable from -23°C to -7°C
Drain evaporator pan	Fin & Tube type
Effective capacity	401L
Refrigerant	R404a
Door / Shelf	3 doors / 6 shelves
Ambient temperature	5 - 38°C
Heat rejection	704W
Castors	Comes standard with 76mm castors = 115mm floor clearance

Product Range		
PART NO.	DESCRIPTION	LIST PRICE
97000152	FTC-180-MNA	

FTC-180MNA COUNTER FREEZER

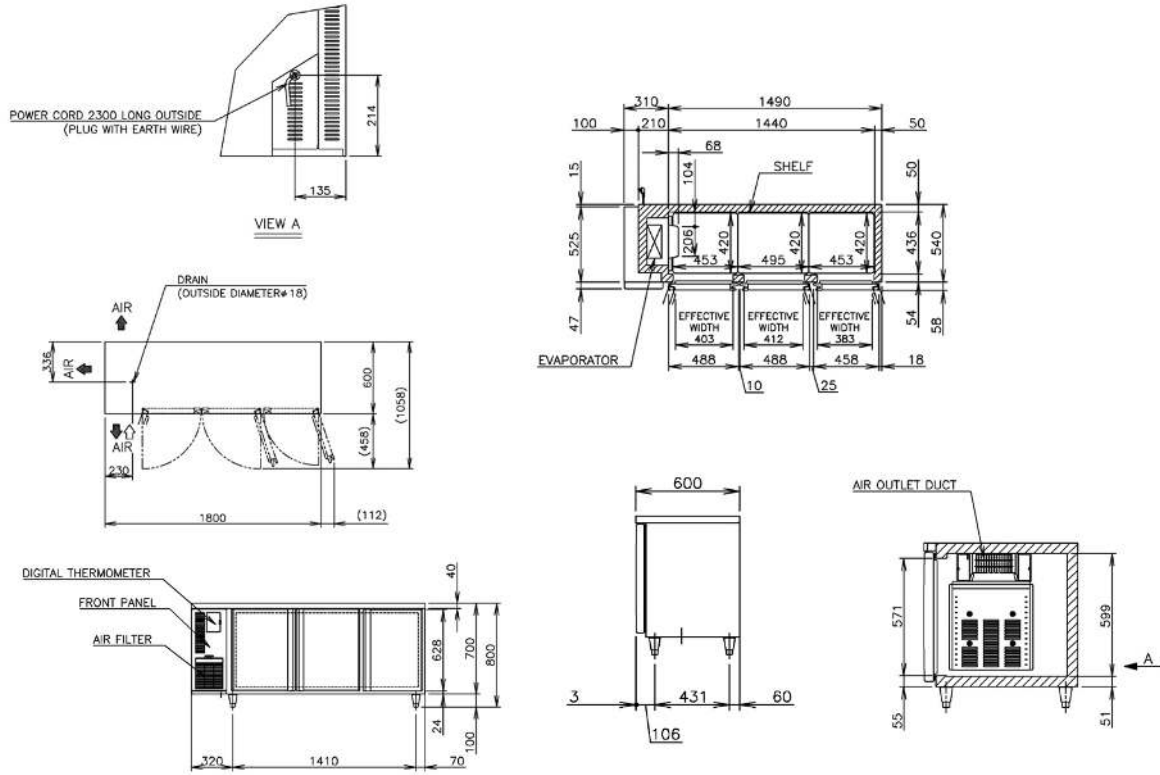

COMMERCIAL SERIES UPRIGHT REACH IN REFRIGERATION & FREEZERS

Hoshizaki refrigeration and freezer products are designed for professional kitchens who demand a reliable easy to maintain product with a low cost of ownership.



Easy Cleaning

Removable door gaskets for easy cleaning without the need for tools.



Adjustable Shelves

The counter offers 4 per door on upright cabinets (includes bottom shelf).



Hygienic Design

Dished stainless interior and base with rounded edges for easy cleaning.



User friendly controller

Control panel with digital thermometer / thermostat for accurate control and easy reading. A transparent plastic cover protects against accidental adjustment of temperature and fluid spillage.



Easy Maintenance

Conveniently located air filters on all cabinets.

HRE-77MA UPRIGHT REFRIGERATOR



<i>Product Specifications</i>	
<i>Weight</i>	Net: 98kg Gross: 120kg
<i>Ac Supply Voltage</i>	220 - 240V / 50Hz
<i>Interior / Exterior</i>	Stainless steel (ABS plastic interior doors)
<i>Amperage</i>	10A
<i>Refrigeration System</i>	Forced Air Circulation
<i>Defrost System</i>	Off Cycle
<i>Temperature control</i>	Microprocessor adjustable from -2°C to 12°C
<i>Drain Evaporator Pan</i>	Fin & Tube type
<i>Effective capacity</i>	546L
<i>Refrigerant</i>	R134a
<i>Heat Rejection</i>	410W
<i>Ambient temperature</i>	5°C to 43°C
<i>Castors</i>	Comes standard with Urethane 76mm castors = 115mm floor clearance

<i>Product Range</i>		
<i>PART NO.</i>	<i>DESCRIPTION</i>	<i>LIST PRICE</i>
97000030	HRE-77-MA	

HRE-77MA UPRIGHT REFRIGERATOR

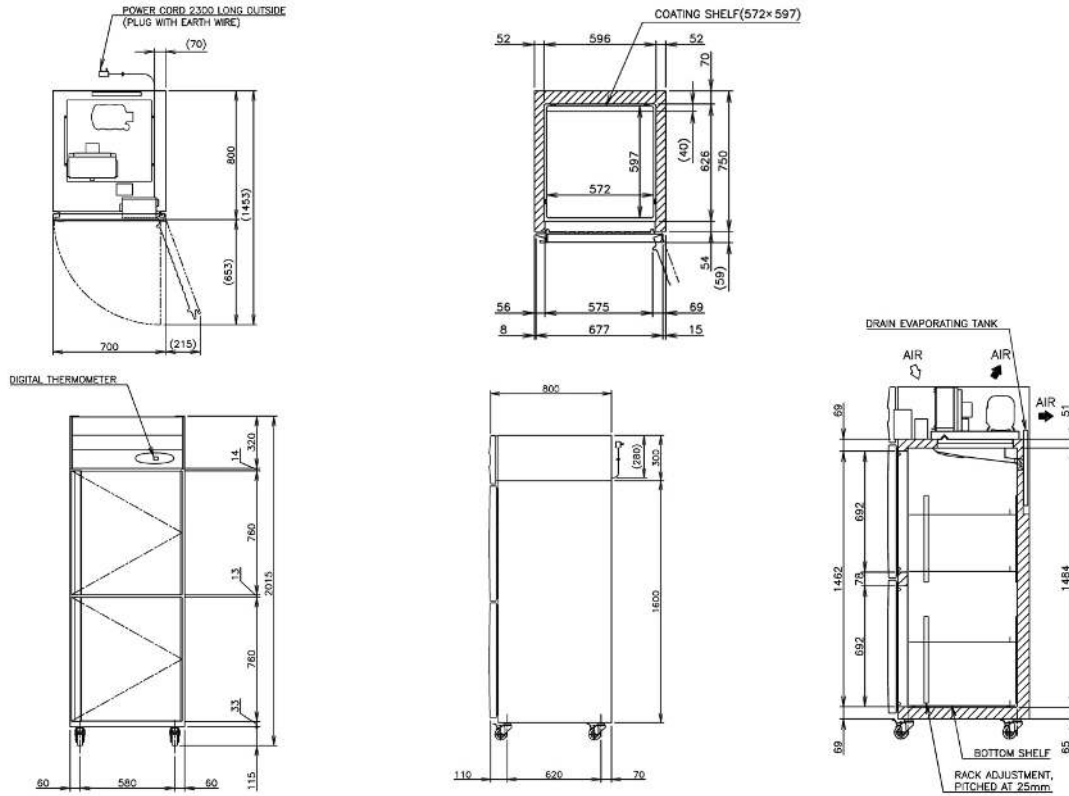

HFE-77MA UPRIGHT FREEZER



<i>Product Specifications</i>	
<i>Weight</i>	Net: 102kg Gross: 124kg
<i>Ac supply voltage</i>	220 - 240V / 50Hz
<i>Interior / Exterior</i>	Stainless steel (ABS plastic interior doors)
<i>Amperage</i>	10A
<i>Refrigeration System</i>	Forced Air Circulation
<i>Defrost system</i>	Heater
<i>Temperature control</i>	Microprocessor adjustable from -23°C to -7°C
<i>Drain Evaporator Pan</i>	Fin & Tube type
<i>Castor</i>	Urethane (76mm DIA, 115mm High)
<i>Effective capacity</i>	546L
<i>Refrigerant</i>	R404a
<i>Heat Rejection</i>	670W
<i>Ambient temperature</i>	5°C to 43°C
<i>Castors</i>	Comes standard with Urethane 76mm castors = 115mm floor clearance

<i>Product Range</i>		
<i>PART NO.</i>	<i>DESCRIPTION</i>	<i>LIST PRICE</i>
97000130	HFE-77-MA	



HFE-77MA UPRIGHT FREEZER

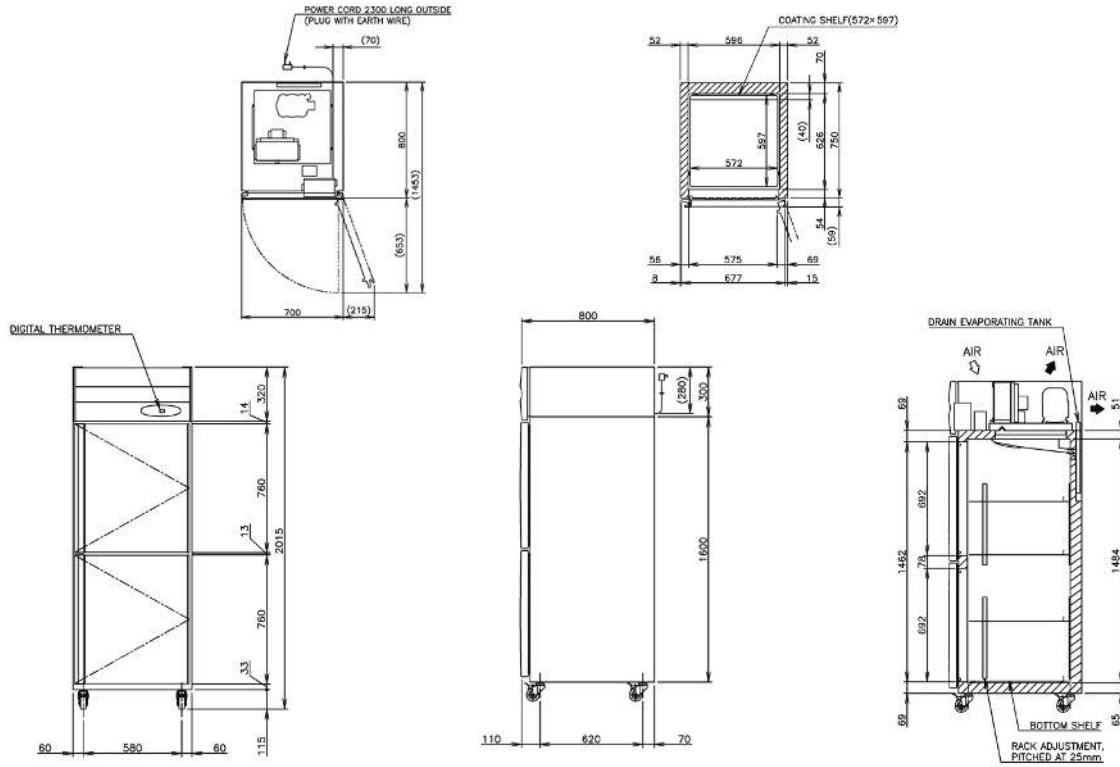

HRE-127MA UPRIGHT REFRIGERATOR



<i>Product Specifications</i>	
<i>Weight</i>	Net: 141kg Gross: 172kg
<i>Ac Supply Voltage</i>	220 - 240V / 50Hz
<i>Interior / Exterior</i>	Stainless steel (ABS plastic interior doors)
<i>Amperage</i>	10A
<i>Refrigeration system</i>	Forced air circulation
<i>Defrost system</i>	Off cycle
<i>Temperature control</i>	Microprocessor adjustable from -2°C to 12°C
<i>Drain Evaporator Pan</i>	Fin & Tube type
<i>Effective capacity</i>	1080L
<i>Refrigerant</i>	R134a
<i>Heat Rejection</i>	560W
<i>Ambient Temperature</i>	5°C to 43°C
<i>Castors</i>	Comes standard with Urethane 76mm castors = 115mm floor clearance

<i>Product Range</i>		
<i>PART NO.</i>	<i>DESCRIPTION</i>	<i>LIST PRICE</i>
97000031	HRE-127-MA	

HFE-127MA UPRIGHT FREEZER



<i>Product Specifications</i>	
<i>Weight</i>	Net: 146kg Gross: 177kg
<i>Ac Supply voltage</i>	220 - 240V / 50Hz
<i>Interior / exterior</i>	Stainless steel (ABS plastic interior doors)
<i>Amperage</i>	10A
<i>Refrigeration System</i>	Forced air circulation
<i>Defrost System</i>	Heater
<i>Temperature control</i>	Microprocessor adjustable from -23°C to -7°C
<i>Drain Evaporator Pan</i>	Fin & Tube type
<i>Effective capacity</i>	1070L
<i>Refrigerant</i>	R404a
<i>Heat Rejection</i>	1030W
<i>Ambient temperature</i>	5°C - 43°C
<i>Castors</i>	Comes standard with 76mm castors = 115mm floor clearance

<i>Product Range</i>		
<i>PART NO.</i>	<i>DESCRIPTION</i>	<i>LIST PRICE</i>
97000131	HFE-127-MA	

HFE-127MA UPRIGHT FREEZER

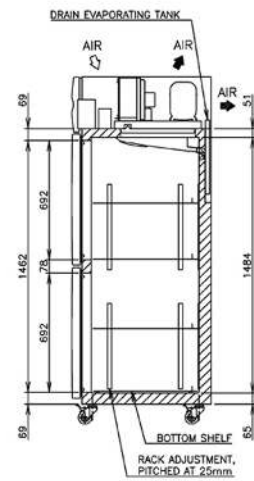
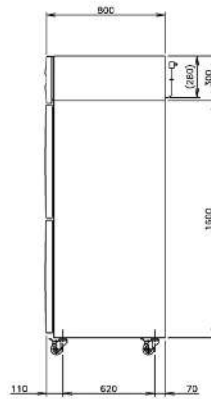
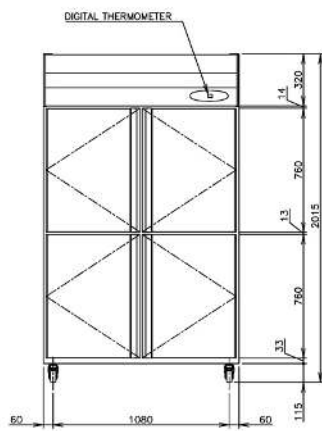
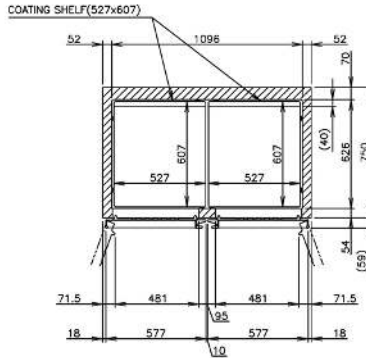
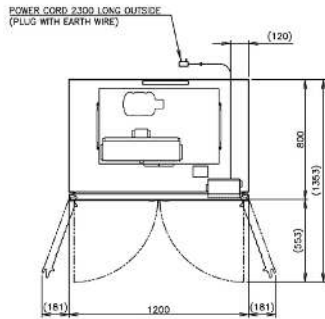

HRE-147MA UPRIGHT REFRIGERATOR



<i>Product Specifications</i>	
<i>Weight</i>	Net: 159kg Gross: 193kg
<i>AC Supply Voltage</i>	220-240V / 50Hz
<i>Interior / Exterior</i>	Stainless steel (ABS plastic interior doors)
<i>Amperage</i>	10A
<i>Refrigeration system</i>	Forced Air Circulation
<i>Defrost System</i>	Off cycle
<i>Temperature Control</i>	Microprocessor adjustable from -2°C to 12°C
<i>Drain Evaporator Pan</i>	Fin & Tube type
<i>Effective Capacity</i>	1217L
<i>Refrigerant</i>	R134a
<i>Heat Rejection</i>	610W
<i>Ambient Temperature</i>	5°C to 43°C
<i>Castors</i>	Comes standard with Urethane 76mm castors = 115mm floor clearance

<i>Product Range</i>		
<i>PART NO.</i>	<i>DESCRIPTION</i>	<i>LIST PRICE</i>
97000032	HRE-147-MA	

HRE-147MA UPRIGHT REFRIGERATOR

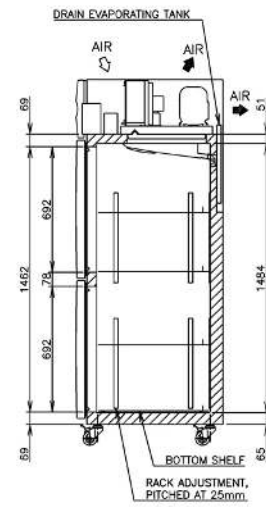
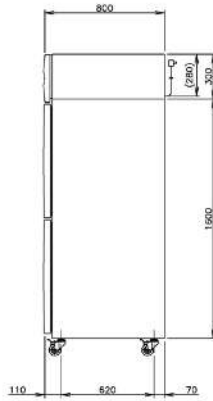
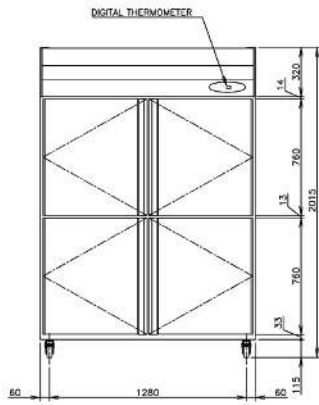
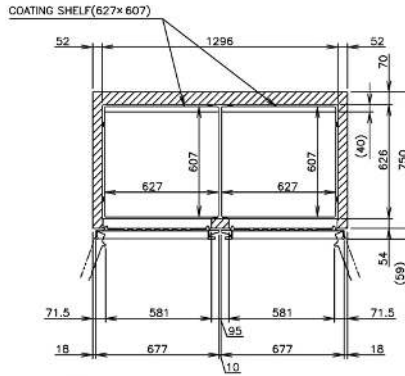
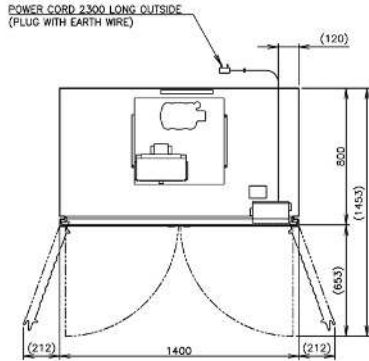

HFE-147MA UPRIGHT FREEZER



<i>Product Specifications</i>	
<i>Weight</i>	Net: 164kg Gross: 198kg
<i>AC Supply Voltage</i>	220-240V / 50Hz
<i>Interior/ Exterior</i>	Stainless steel (ABS plastic interior doors)
<i>Amperage</i>	10A
<i>Refrigeration System</i>	Forced air circulation
<i>Defrost System</i>	Heater
<i>Temperature Control</i>	Microprocessor adjustable -23°C to -7°C
<i>Drain Evaporator Pan</i>	Fin & Tube type
<i>Effective Capacity</i>	1203L
<i>Refrigerant</i>	R404a
<i>Heat Rejection</i>	1150W
<i>Ambient Temperature</i>	5°C - 43°C
<i>Castors</i>	Comes standard with Urethane 76mm castors = 115mm floor clearance

<i>Product Range</i>		
<i>PART NO.</i>	<i>DESCRIPTION</i>	<i>LIST PRICE</i>
97000132	HFE-147-MA	

HFE-147MA UPRIGHT FREEZER

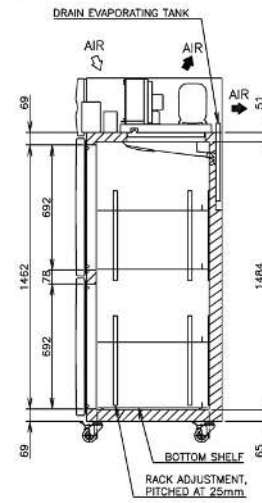
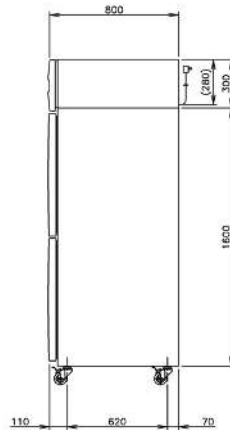
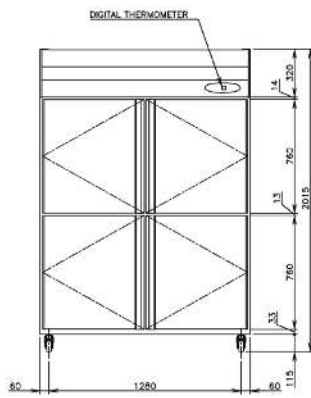
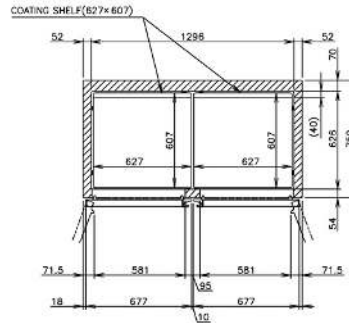
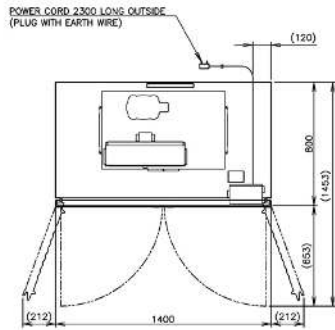

HRE-187MA UPRIGHT REFRIGERATOR



<i>Product Specifications</i>	
<i>Weight</i>	Net: 184kg Gross: 226kg
<i>Ac supply voltage</i>	220 - 240V / 50Hz
<i>Interior / Exterior</i>	Stainless steel (ABS plastic interior doors)
<i>Amperage</i>	10A
<i>Refrigeration system</i>	Forced air circulation
<i>Defrost system</i>	Off cycle
<i>Temperature control</i>	Microprocessor adjustable from -2°C to 12°C
<i>Drain Evaporator Fan</i>	Fin & Tube type
<i>Effective capacity</i>	1600L
<i>Refrigerant</i>	R134a
<i>Heat Rejection</i>	790W
<i>Ambient Temperature</i>	5°C - 43°C
<i>Castors</i>	Comes standard with Urethane 76mm castors = 115mm floor clearance

<i>Product Range</i>		
<i>PART NO.</i>	<i>DESCRIPTION</i>	<i>LIST PRICE</i>
97000033	HRE-187-MA	

HRE-187MA UPRIGHT REFRIGERATOR

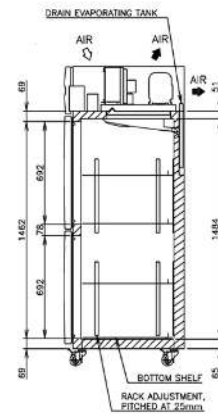
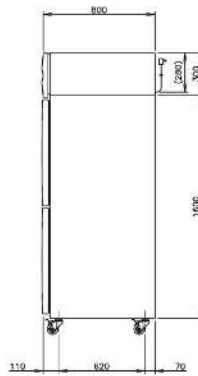
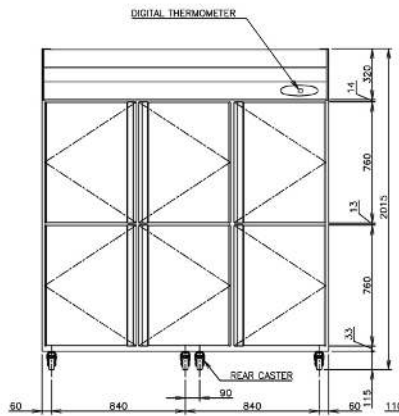
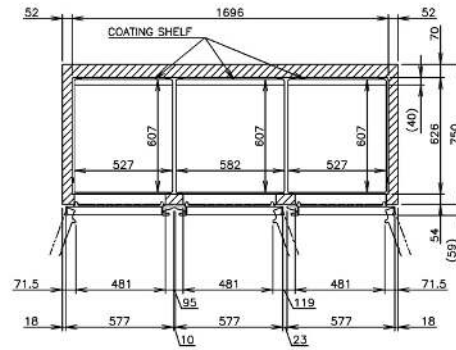
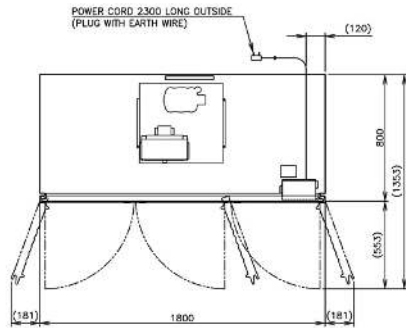

HFE-187MA UPRIGHT FREEZER



<i>Product Specifications</i>	
<i>Weight</i>	Net: 196kg Gross: 238kg
<i>AC Supply voltage</i>	220 - 240V / 50Hz
<i>Interior / Exterior</i>	Stainless steel (ABS plastic interior doors)
<i>Amperage</i>	10A
<i>Refrigeration system</i>	Forced air circulation
<i>Defrost system</i>	Heater
<i>Temperature control</i>	Microprocessor adjustable from -23°C to -7°C
<i>Drain evaporator fan</i>	Fin & Tube type
<i>Effective capacity</i>	1600L
<i>Refrigerant</i>	R404a
<i>Heat Rejection</i>	1210W
<i>Ambient temperature</i>	5°C - 43°C
<i>Castors</i>	Comes standard with Urethane 76mm castors = 115mm floor clearance

<i>Product Range</i>		
<i>PART NO.</i>	<i>DESCRIPTION</i>	<i>LIST PRICE</i>
97000133	HFE-187-MA	

HFE-187MA UPRIGHT FREEZER

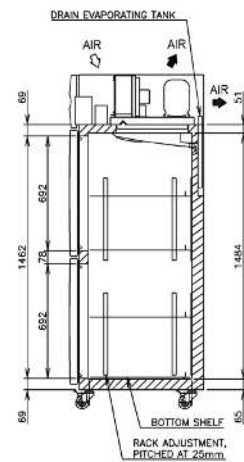
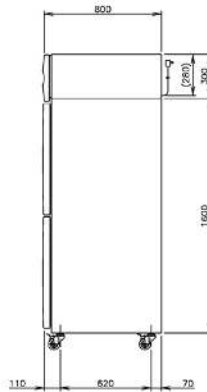
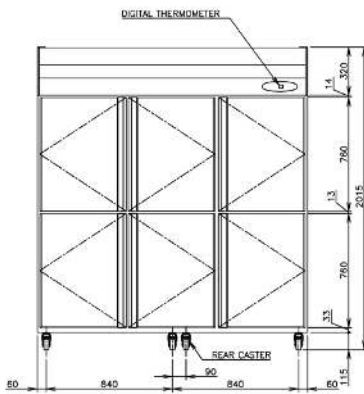
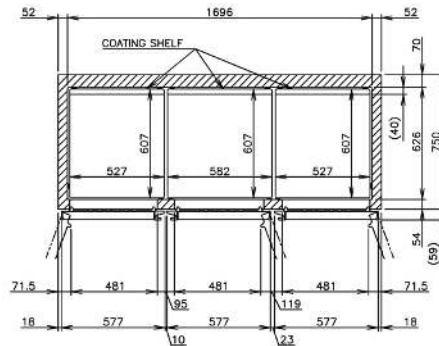
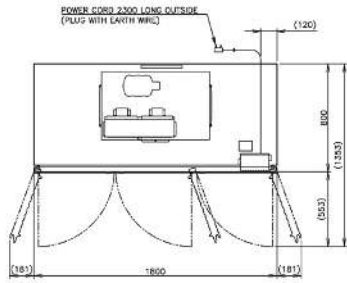

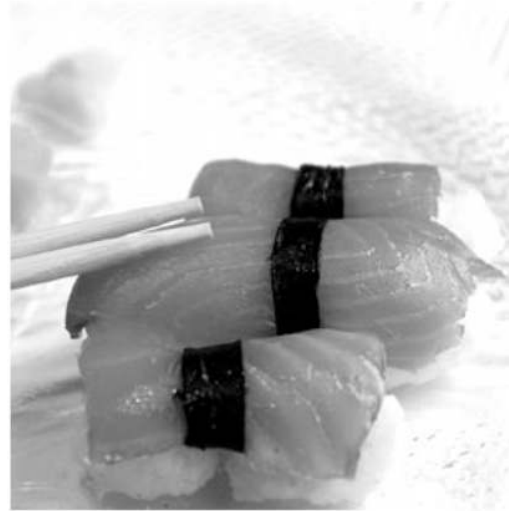

SUSHI CABINETS



Hoshizaki Foodservice Equipment

www.hoshizaki.com.au

SUSHI CABINETS

With rounded glass windows and black exterior Hoshizaki sushi cases provide an eye catching point of sales display to attract customers.

SUSHI PRODUCT HIGHLIGHTS

Hoshizaki's HNC Sushi Cabinets are designed to be aesthetically appealing. They are produced to sit on counter tops, with a contemporary and modern design that looks great as well keeping your sushi cooled at exactly the right temperature.



- Stable humidity and temperature levels are maintained at all times, instead of forced air circulation methods that dry out and ruin displayed sushi. Your sushi will stay fresh longer and taste as good as it looks.
- Hoshizaki machines will not defrost and allow condensation to drip onto the sushi displayed within them, protecting the integrity of the product at all times.
- 12 month warranty on all Hoshizaki sushi cabinets.



HNC-120BE-L COUNTER SHOWCASE



<i>Product Specifications</i>	
<i>EXTERIOR DIMENSIONS</i>	Width: 1200mm Depth: 345mm Height: 270mm
<i>INTERIOR DIMENSIONS</i>	Width: 845mm Depth: 288mm (floor) Height: 157mm
<i>WEIGHT</i>	Net: 32kg Packed: 44kg
<i>AC SUPPLY VOLTAGE</i>	220 - 240V / 50Hz 10Amps
<i>RATED AMPERAGE</i>	1.1A
<i>SATURATION TEMPERATURE</i>	Approx 4°C (Ambient temp 27°C, no load)
<i>NET CAPACITY</i>	42litres
<i>AMBIENT TEMPERATURE</i>	10°C - 30°C
<i>REFRIGERATION SYSTEM</i>	Convection Cooling

<i>Product Range</i>		
<i>PART NO.</i>	<i>DESCRIPTION</i>	<i>LIST PRICE</i>
91000034	HNC-120BE-L	



HNC-120BE-L COUNTER SHOWCASE

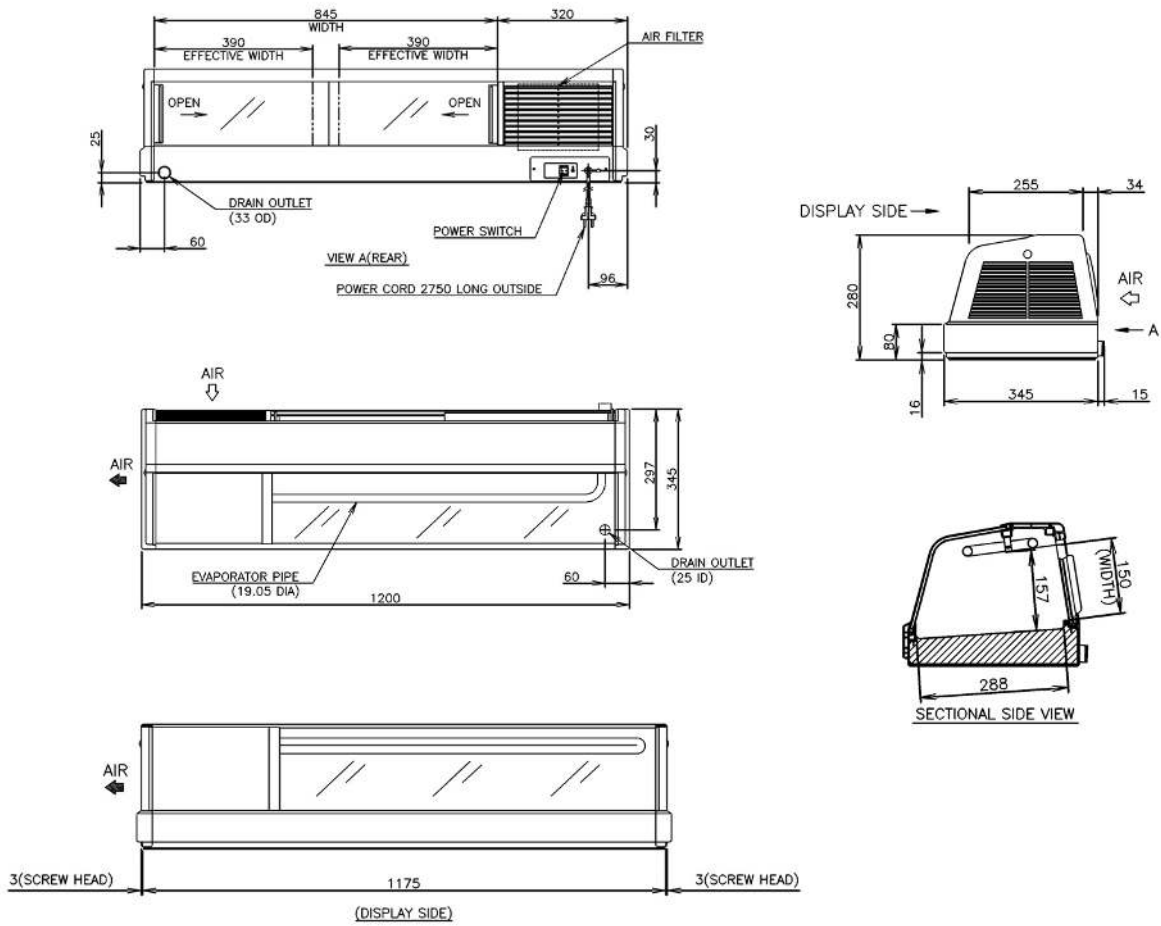

HNC-150BE-L COUNTER SHOWCASE



<i>Product Specifications</i>	
<i>EXTERIOR DIMENSIONS</i>	Width: 1500mm Depth: 345mm Height: 270mm
<i>INTERIOR DIMENSIONS</i>	Width: 1145mm Depth: 288mm (floor) Height: 157mm
<i>WEIGHT</i>	Net: 37kg Packed: 52kg
<i>AC SUPPLY VOLTAGE</i>	220 - 240V / 50Hz 10Amps
<i>RATED AMPERAGE</i>	1.1A
<i>SATURATION TEMPERATURE</i>	Approx 4°C (Ambient temp 30°C, no load)
<i>NET CAPACITY</i>	57litres
<i>AMBIENT TEMPERATURE</i>	10°C - 30°C
<i>REFRIGERATION SYSTEM</i>	Convection Cooling

<i>Product Range</i>		
<i>PART NO.</i>	<i>DESCRIPTION</i>	<i>LIST PRICE</i>
91000035	HNC-150BE-L	



HNC-150BE-L COUNTER SHOWCASE

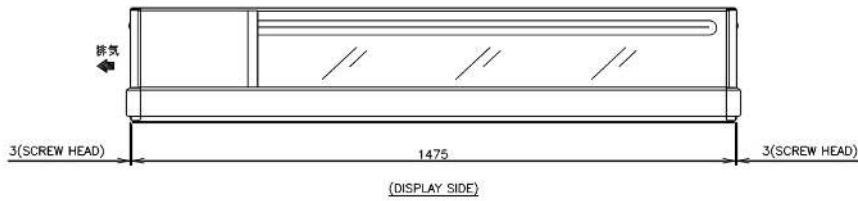
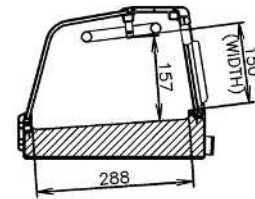
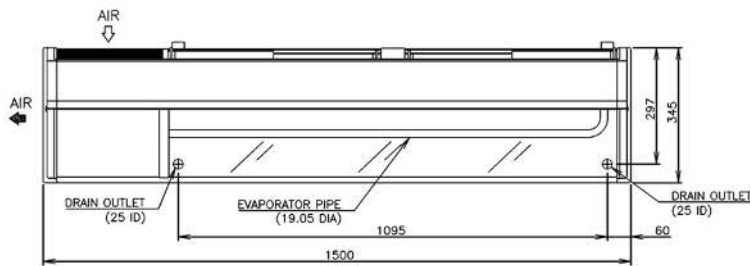
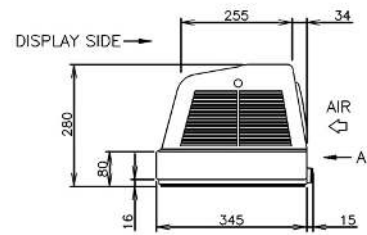
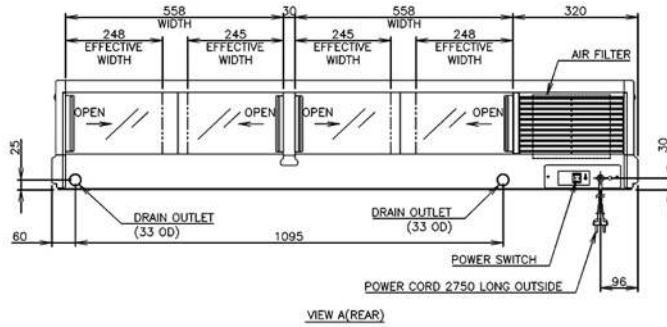

HNC-180BE-R-B COUNTER SHOWCASE



<i>Product Specifications</i>	
<i>EXTERIOR DIMENSIONS</i>	Width: 1800mm Depth: 345mm Height: 270mm
<i>INTERIOR DIMENSIONS</i>	Width: 1445mm Depth: 288mm (floor) Height: 157mm
<i>WEIGHT</i>	Net: 42kg Packed: 60kg
<i>AC SUPPLY VOLTAGE</i>	220 - 240V / 50Hz 10Amps
<i>SATURATION TEMPERATURE</i>	Approx 4°C (Ambient temp 27°C, no load)
<i>NET CAPACITY</i>	72L
<i>AMBIENT TEMPERATURE</i>	10°C - 30°C
<i>REFRIGERATION SYSTEM</i>	Convection Cooling

<i>Product Range</i>		
<i>PART NO.</i>	<i>DESCRIPTION</i>	<i>LIST PRICE</i>
91000037	HNC-180BE-R-B	



HNC-180BE-R-B COUNTER SHOWCASE

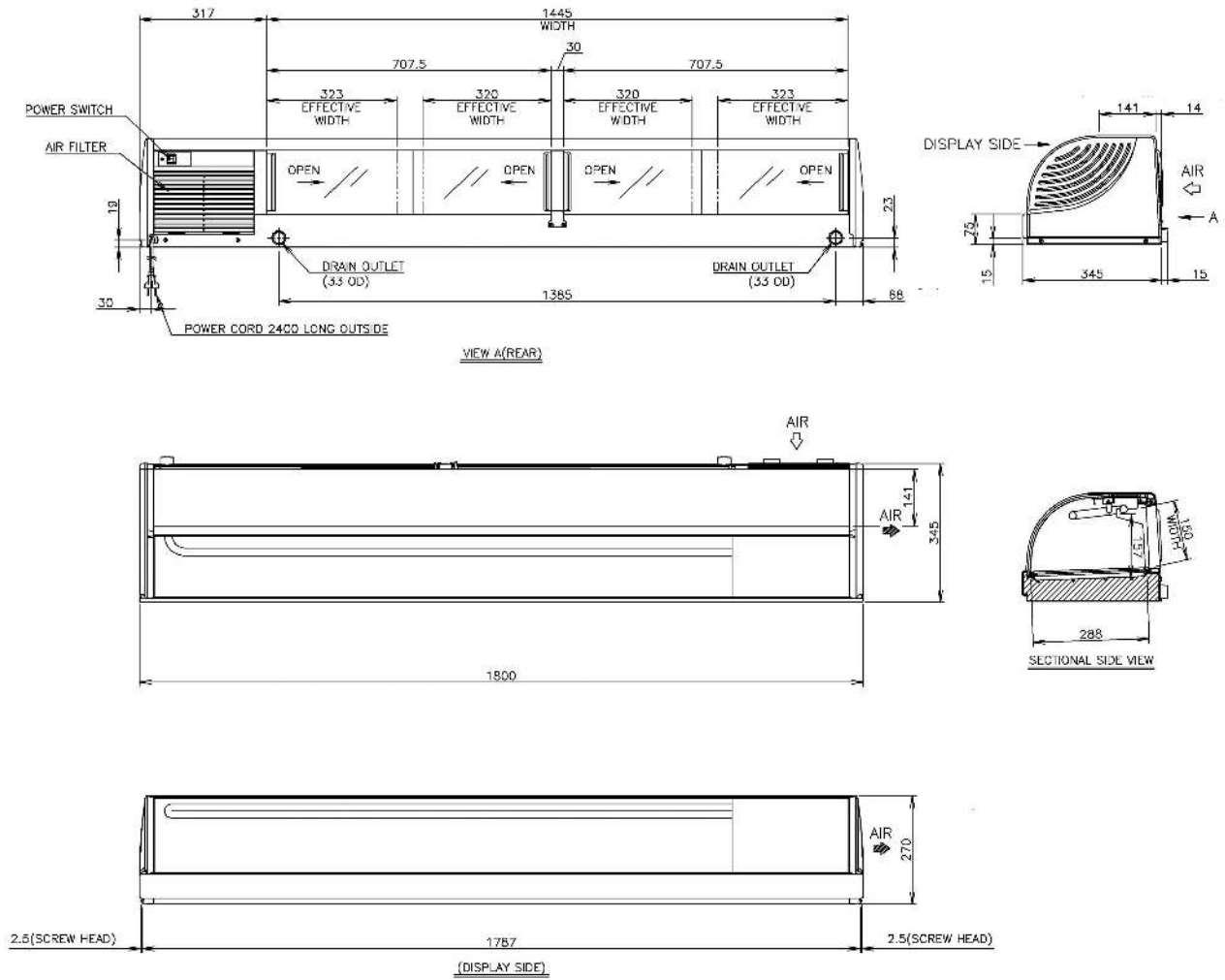

HOSHIZAKI SPARE PARTS

National Ice Parts is our authorised Hoshizaki genuine factory parts supplier for Australia.

Contact them for all your parts requirements for Hoshizaki ice machines and refrigerators.

TOLL FREE NUMBER - 1800 206 235

PH: 02 8677 0222

FAX: 02 8677 9978

EMAIL: INFO@NATIONALICEPARTS.COM.AU

ADDRESS: UNIT 7, 2 RICHARD CLOSE, NORTH ROCKS NSW 2151

WEBSITE: WWW.NATIONALICEPARTS.COM.AU



ACCREDITATION AND TERMS

ACCREDITATIONS

HACCP

- Hazard Analysis Critical Control Point (HACCP) is the main platform for International legislation and good manufacturing practices for all sectors of the food industry.
- HACCP also forms a key component of many certified compliance standards and is recognized as a main element of international trade in food products.
- HACCP is a risk management tool recognized internationally for use in the pro active management of food safety issues.



WATERMARK

The WaterMark Code requires that plumbing and drainage products must have a WaterMark certification. Without this certification, they cannot be legally installed in accordance with Australian State and Territory plumbing legislation.

A WaterMark licence confirms that the product complies with the requirements of the Plumbing Code of Australia and the specifications listed in relevant Australian Standards. The specifications relate to the quality of the product, including aspects of health and safety, and warrant that it is fit for purpose. Use of the WaterMark is not limited to goods manufactured in Australia; it may be used on goods imported into Australia.



State, territory and local governments collectively ensure compliance with the Plumbing Code, including the requirement that only WaterMarked products are installed. Plumbers are required to meet the appropriate standards under their licence, with inspections carried out on building sites, mainly in relation to new buildings, by plumbing regulators.

Australian consumers can be confident about the quality of plumbing and draining products certified with the WaterMark.

TERMS

Refer to our full Terms and Conditions on our website: <http://lancerbeverage.com/footer/terms-and-conditions/terms-and-conditions>

The prices in this catalogue are to be used as a guide only; they do not incorporate all Hoshizaki Lancer products. All prices are GST exclusive. For information on any products not listed, please contact your local branch. Descriptions and specifications are subject to change at any time, without notice. Illustrations for demonstration purposes only. Elements of the pictures shown within this catalogue may not be standard and could incur additional charges.

For warranties please refer to the product pages on our website.

Copyright © 2014 Hoshizaki Lancer Pty Ltd All rights reserved. E&OE.





Hoshizaki Foodservice Equipment

HOSHIZAKI LANCER

PO Box 331 Welland SA 5007

5 Toogood Avenue Beverley SA 5009

T+ 61 8 8268 1388

F+ 61 8 8268 1978

info@hoshizaki.com.au

www.hoshizaki.com.au

11 Sep 2017