



DRB100

ICE STORAGE BIN WITH TROLLEYS

The DRB100 is a stainless steel structure with two 108kg capacity polyethylene moulded trolleys for transporting ice cubes or flakes.

When coupled with a modular head, the DRB100 generously stores ice to meet peak demand times for a range of applications.

Can be coupled with: TM250/450, G280/510 (x2), M350/600.

STANDARD FEATURES

- 108kg storage capacity per trolley
- Can be coupled with a range of Brema modular ice machine heads
- Stainless steel structure
- Polyethylene moulded trolleys

STANDARD ACCESSORIES

- Drainage hose
- Plastic Ice Scoop



DIMENSIONS

1560W x 1060D x 1484H mm

Clearances: Rear: 100mm Sides: 100mm

CONNECTIONS

24mm Water outlet

TECHNICAL DATA

Storage Capacity: 108kg

Weight: 135kg

USABLE WITH MODULAR HEADS

TM250/450, G280/510 (x2), M350/600

SPECIFICATIONS ARE SUBJECT TO CHANGE WITHOUT NOTICE.

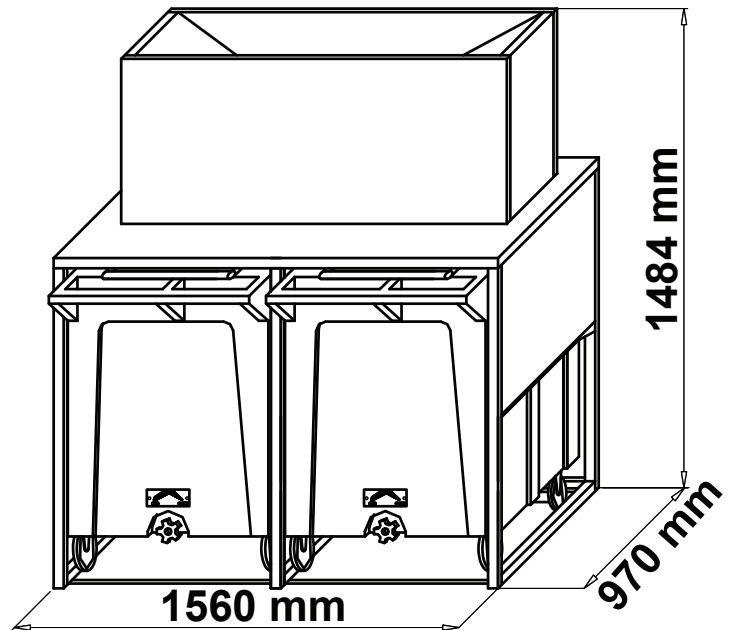

National Head Office
156 Swann Drive
Derrimut VIC 3030
Tel: +61 3 8369 4600
Fax: +61 3 8369 4695
www.comcater.com.au

Melbourne
96-100 Tope Street
South Melbourne VIC 3205
Tel: +61 3 8369 4600
Fax: +61 3 8699 1299

Sydney
20/4 Avenue of the Americas
Newington, NSW 2127
Tel: +61 2 9748 3000
Fax: +61 2 9648 4762

Brisbane
1/62 Borthwick Avenue
Murarrie QLD 4172
Tel: +61 7 3399 3122
Fax: +61 7 3399 5311

Perth
Unit 16, 7 Abrams Street
Balcatta, WA 6021
Tel: +61 8 6217 0700
Fax: +61 8 6217 0799

from the world of Comcater!